

Council Meeting for March 7, 2022



CITY COUNCIL AGENDA

March 7, 2022

Final Agenda

7:00 P.M.

Note: All items presented are subject to final action.

PUBLIC FORUM

PETITION

By the Quincy Humane Society requesting to conduct a raffle and have the bond requirement waived from now to April 9, 2022. The City Clerk recommends approval of the permit.

MONTHLY REPORTS

BANK STATEMENTS OF CONDITIONS

RESOLUTIONS

Central Services Director, Engineering and Utilities Director, and the Central Services Committee recommending approval of the low quote from The Lawn Guys of Quincy in the amount of \$32,445.00 for lawn maintenance of city owned properties and right of ways.

Chief of Police and Police Aldermanic Committee recommending approval to purchase 10,000 rounds of 5.56x45 and 10,000 rounds of 9mm practice ammunition from Defense Logistics LLC of North Kansas City, MO, for a total cost of \$7,901.25.

Chief of Police and Police Aldermanic Committee recommending approval to purchase a Loki MK2 tactical drone package from Aardvark Tactical of La Verne, CA, for a total cost of \$12,555.00.

Resolution establishing a Whistleblower Reporting and Anti-Retaliation Policy for the City of Quincy.

Resolution authorizing application for a Public Transportation Capital Assistance Grant under the Illinois Department of Transportation to offset certain transportation facility capital costs of City of Quincy.

Utilities and Engineering Director and Utilities Committee recommending approval to finance improvements to the Combined Sewer Overflow System with a \$9 million loan through the Illinois Environmental Protection Agency's Water Pollution Control Loan Program.

Utilities and Engineering Director and Utilities Committee recommending approval of the proposal from Crawford, Murphy and Tilly of Springfield, IL for the second phase of improvements which includes the expansion of the Waste Water Treatment Plant pump station and structures for an amount not to exceed \$330,000.00.

Utilities and Engineering Director and Utilities Committee recommending approval of the invoice from Midwest Meter, Inc., of Edinburg, IL in the amount of \$113,130.40 for the purchase of 10 six inch fire service assembly water meters to replace aging commercial meters.

Utilities and Engineering Director and Central Services Committee requesting approval of a joint agreement between the City of Quincy and County of Adams for the purchase of right-of-way, construction of a PCC pavement roundabout, road widening and resurfacing, installation of storm sewers, sidewalk, roadway lighting and pavement markings, and other construction related items at the intersection of 48th & State Street.

Utilities and Engineering Director and Central Services Committee requesting the appropriation of \$69,462.00 for the purchase of right-of-way and relocation of a natural gas main for the proposed 48th and State Street intersection improvements.

Utilities and Engineering Director and Central Services Committee recommending approval of the appropriation of \$520,000.00 of REBUILD Illinois bond funds for the replacement of the Harrison Street bridge (east of 24th Street) that crosses Curtis Creek.

Resolution to accept a Quit Claim Deed from the owner of the property commonly known as 426 College.

Resolution to terminate the Funding Agreement between the Illinois Housing Development Authority and the City of Quincy under the Abandoned Residential Property Municipality Relief Program.

ORDINANCE

Ward An Ordinance Amending The District Map Which Is Made A Part Of Section 162.002 Of The
3 Municipal Code Of The City Of Quincy Of 2015 (Re-zoning of 4701-4729 Broadway Street).

REPORT OF FINANCE



OFFICE OF THE CITY CLERK
CITY OF QUINCY
LAURA OAKMAN

CITY HALL SUITE 129
730 MAINE STREET
QUINCY, IL 62301-4956

PHONE (217) 228-4510
FAX (217) 221-3664
LOakman@ci.quincy.il.us

March 1, 2022

TO THE HONORABLE MAYOR AND MEMBERS OF THE CITY COUNCIL:

I herewith submit a report of City Licenses and Permits issued by me during the month of February, 2022 the periods for which they were issued together with the fees collected and subsequently paid to the City Treasurer:

<u>#</u>	<u>NAME</u>	<u>PERIOD</u>	<u>AMOUNT</u>		<u>TOTAL</u>
			<u>EACH</u>		
1	Firework	1 day	\$ 50.00	\$	50.00
1	Raffle	1 Year	\$ 60.00	\$	60.00
1	Raffle	120 days	\$ 30.00	\$	30.00
2	Raffle	90 days	\$ 20.00	\$	40.00
3	Raffle	30 days	\$ 10.00	\$	30.00
Total Collected by the Treasurer's Office				\$	210.00

Respectfully submitted,

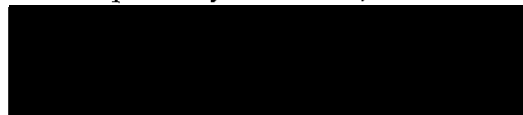

LAURA OAKMAN
City Clerk

LO:ak

**City of Quincy
Department of Central Services**



**Kevin McClean
Director**

**2020 Jennifer Road
Quincy, IL 62301
Phone: (217) 228-4520**

FORESTRY MONTHLY REPORT

Date: March 2, 2022

To the Honorable Mayor and City Council:

The following is a report of work done by the Forestry Department for the month of February

Trees Removed – 13 total
Concrete Trip/Fall Hazard – 0
Sewer Issue – 0
Water Issue – 0
Power Line Interference – 0
Dead/Dying – 10
Blocked Sign – 0
Safety Hazard – 3
Construction Work – 0

Stumps Removed – 0

Trees Trimmed – 7

Respectfully submitted,

Kevin McClean
Director
Department of Central Services

**City of Quincy
Department of Central Services**



**Kevin McClean
Director**

**2020 Jennifer Road
Quincy, IL 62301
Phone: (217) 228-4520**

**SIGN AND PAINT
MONTHLY REPORT**

DATE: March 2, 2022

To the Honorable Mayor and City Council:

The following is the report of the Sign and Paint Department for the month of February

City Signs Replaced – 1

New Signs – 41

City Blocks Striped – 0

Feet of Curbs Painted – 0

Intersections Painted – 0

Parking Lots Painted - 0

Handicapped Parking Stalls Painted - 0

Barrels of Yellow Paint Used – 0

Barrels of White Paint Used – 0

Respectfully submitted,

Kevin McClean
Director

City of Quincy Department of Central Services



Kevin McClean
Director

2020 Jennifer Road
Quincy, IL 62301
Phone: (217) 228-4520

RECYCLING DIVISION MONTHLY REPORT

Date: March 1, 2022

To the Honorable Mayor and City Council:

The following is a report of materials and quantities collected from the residential waste system for the month of February

<u>MATERIAL</u>	<u>POUNDS</u>	<u>TONS</u>
Fiber	75,160	37.58
Non-Fiber	33,200	16.60

Respectfully submitted,

Kevin McClean
Director
Department of Central Services

**City of Quincy
Department of Central Services**



**Kevin McClean
Director**

**2020 Jennifer Road
Quincy, IL 62301
Phone: (217) 228-4520**

FORESTRY MONTHLY REPORT

Date: February 8, 2022

To the Honorable Mayor and City Council:

The following is a report of work done by the Forestry Department for the month of January

Trees Removed – 3 total
Concrete Trip/Fall Hazard – 0
Sewer Issue – 0
Water Issue – 1
Power Line Interference – 0
Dead/Dying – 2
Blocked Sign – 0
Safety Hazard – 0
Construction Work – 0

Stumps Removed – 19

Trees Trimmed – 15

Respectfully submitted,

Kevin McClean
Director
Department of Central Services

**City of Quincy
Department of Central Services**



**Kevin McClean
Director**

**2020 Jennifer Road
Quincy, IL 62301
Phone: (217) 228-4520**

**SIGN AND PAINT
MONTHLY REPORT**

DATE: February 7, 2022

To the Honorable Mayor and City Council:

The following is the report of the Sign and Paint Department for the month of January

City Signs Replaced – 2

New Signs – 43

City Blocks Striped – 0

Feet of Curbs Painted – 0

Intersections Painted – 0

Parking Lots Painted - 0

Handicapped Parking Stalls Painted - 0

Barrels of Yellow Paint Used – 0

Barrels of White Paint Used – 0

Respectfully submitted,

Kevin McClean
Director

City of Quincy Department of Central Services



Kevin McClean
Director

2020 Jennifer Road
Quincy, IL 62301
Phone: (217) 228-4520

RECYCLING DIVISION MONTHLY REPORT

Date: February 9, 2022

To the Honorable Mayor and City Council:

The following is a report of materials and quantities collected from the residential waste system for the month of January

<u>MATERIAL</u>	<u>POUNDS</u>	<u>TONS</u>
Fiber	108,220	54.11
Non-Fiber	44,620	22.31

Respectfully submitted,

Kevin McClean
Director
Department of Central Services

RESOLUTION

WHEREAS, the city of Quincy is responsible for lawn maintenance of all city owned properties and certain right-of-way locations; and

WHEREAS, the city did seek proposals for lawn maintenance services; and

WHEREAS, the Central Services Committee reviewed all of the proposals; and

WHEREAS, The Lawn Guys provided the lowest proposal in the amount of \$32,445.00 and meets the specified requirements; now

THEREFORE BE IT RESOLVED, the Central Services Director, Engineering and Utilities Director, and the Central Services Committee recommends to the Mayor and City Council that the low quote from The Lawn Guys of Quincy, Illinois in the amount of \$32,445.00 be accepted.

Kevin McClean
Central Services Director

Jeffrey Conte
Engineering and Utilities Director

March 7, 2022



DEPARTMENT OF POLICE CITY OF QUINCY

From the Office of Robert A. Copley, Chief of Police
530 Broadway - Quincy, Illinois 62301-4058
Phone (217) 228-4480, Fax (217) 221-2269

March 4, 2022

Mayor Mike Troup
Members of the Quincy City Council
Quincy City Hall
730 Maine Street
Quincy, IL 62301

RE: AMMUNITION PURCHASE

Dear Mayor Troup and Members of the Quincy City Council:

The purpose of this letter is to ask for your approval to purchase 10,000 rounds of 5.56x45mm and 10,000 rounds of 9mm ammunition. The total cost of the purchase, including shipping, is estimated at \$7,901.25. We ask that you consider this a "sole source" purchase due to the limited availability of ammunition. This item was included in the Tactical and Firearms Equipment and Ammunition project passed in January's supplemental budget amendment.

The use of deadly force by a police officer is considered a low frequency, high risk practice. It is extremely rare that a police officer is required to discharge his or her duty weapon to defend their life or the life of another. When such an incident does occur, there is a high probability that litigation will result. We take firearms training very seriously, and having practice ammunition available is a key component to an effective firearms training program.

Over the last several years we have cut the amount of budget funds allocated to purchase ammunition. This has resulted in our ammunition inventory being significantly reduced. Another issue we are negotiating is a nationwide shortage of ammunition. Our firearms coordinator, Sgt. Mike Tyler, has reached out to a number of ammunition suppliers for pricing. Nearly every vendor contacted told us that they have no ammunition in stock.

Doing my due diligence, I checked Cheaper than Dirt and found that a box of 5.56x45 ammunition is \$14.98, which is \$4.98 more than the estimate from Defense Logistics. The price of 9mm ammunition is on average \$5.00 more expensive per box than the estimate from Defense Logistics. When I checked the GameMasters website I was prevented from entering the number of rounds we want to buy. A message came up that that read, "We don't have enough on hand for the quantity you selected. Please try again."

"Service – Pride – Dignity"

QUINCY POLICE DEPARTMENT
Mayor Mike Troup
Members of the Quincy City Council
March 4, 2022
Page 2

Defense Logistics LLC, located in North Kansas City, MO, is a law enforcement ammunition supplier that currently has two of the three calibers of ammunition we need in stock. We would like to move forward with the purchase of 10,000 rounds of 5.56x45mm (\$10.00 per 20 round box) and 10,000 rounds of 9mm (\$14.00 per 50 round box) from Defense Logistics LLC for an estimated cost of \$7,901.25.

If you have any questions or concerns, please do not hesitate to contact me. In my absence you may also contact Deputy Chief Pilkington or Deputy Chief Yates. Thank you for your consideration of this request.

Sincerely,



Robert A. Copley
Chief of Police

Cc: Mayor Mike Troup
Mr. Jeff Mays, DAS
Ms. Sheri Ray, Comptroller
Ms. Mary Ann Ervin
Deputy Chief Pilkington

RESOLUTION

WHEREAS, the Quincy Police Department recognizes that deadly force confrontations are low frequency, high risk events; and

WHEREAS, officer-involved shootings are dynamic, spontaneous situations that can occur at any time without warning; and

WHEREAS, the Quincy Police Department has developed a robust and extensive firearms training program that conducts training multiple times each year to prepare officers for such an event; and

WHEREAS, a vital component of a robust and extensive firearms program is the availability of practice ammunition; and

WHEREAS, the Quincy Police Department has cut ammunition funds from our budget the last several years causing our practice ammunition inventory to become significantly reduced; and,

WHEREAS, practice ammunition has become hard to get and more expensive over the last several years; and,

WHEREAS, the Quincy Police Department has established a relationship with Defense Logistics LLC of North Kansas City, MO, who is a supplier of ammunition and currently has two of three calibers we need to purchase in stock; and,

WHEREAS, the Quincy Police Department has checked several other ammunition suppliers that are either more expensive or lack inventory all together; now

THEREFORE BE IT RESOLVED, the Chief of Police and Police Aldermanic Committee recommend to the Mayor and City Council that the Police Department be allowed to purchase 10,000 rounds of 5.56x45 and 10,000 rounds of 9mm practice ammunition from Defense Logistics LLC of North Kansas City, MO, for the total cost of \$7,901.25.

Robert A. Copley
Chief of Police

March 7, 2022



DEPARTMENT OF POLICE CITY OF QUINCY

From the Office of Robert A. Copley, Chief of Police
530 Broadway - Quincy, Illinois 62301-4058
Phone (217) 228-4480, Fax (217) 221-2269

March 4, 2022

Mayor Mike Troup
Members of the Quincy City Council
Quincy City Hall
730 Maine Street
Quincy, IL 62301

RE: LOKI MK2 TACTICAL DRONE PURCHASE

Dear Mayor Troup and Members of the Quincy City Council:

The purpose of this letter is to ask for your approval to purchase a Loki MK2 Drone and a Loki UAV Extension set from Aardvark Tactical of La Verne CA, for \$12,555.00. Aardvark Tactical is the sole source provider of this particular piece of equipment. This item was included in the Tactical and Firearms Equipment and Ammunition project passed in January's supplemental budget amendment.

Ensuring our officers can operate as safe as possible while still doing the dangerous work that comes with being a police officer is important. The Quincy Police Department's Emergency Response Team is responsible for handling all critical incidents involving armed individuals that are wanted by the police, but refuse to submit to arrest. At times these individuals will barricade themselves in a house, garage, or other building, making any attempt to apprehend them extremely dangerous.

This piece of safety equipment will make the work asked of our officers much safer. This drone was recommended to us by the FBI Chicago Field Office SWAT team during a 2021 training event. The FBI has used the drone successfully on operations. The drone is designed for interior searches. The enclosed propellers allow the drone to fly under tables and furniture, as well as in attics and above drop ceilings. The built in camera provides a video feed to the drone pilot and is equipped with infrared LED night vision for operation in low light environments. The drone is also capable of two way audio communications.

Our Emergency Response Team obtained a tactical robot about 20 years ago, which was state of the art at that time. Due to its age, the robot has become unreliable over the last several years and stopped functioning all together about six months ago. The Loki MK2 tactical drone, with its extended capabilities and advanced technology, is the ideal replacement. This equipment will allow our tactical operators to visually clear a structure prior to entry; increasing the likelihood of a safe resolution.

"Service – Pride – Dignity"

QUINCY POLICE DEPARTMENT
Mayor Troup
Members of the Quincy City Council
March 4, 2022
Page 2

The Loki MK2 tactical drone package we want to purchase is a complete drone kit (\$9,500.00) and an extension set that includes additional batteries, charger, USB cables and 8 additional propellers (\$2,980.00). The cost for shipping is \$75.00, bringing the total cost to \$12,555.00. Aardvark provided a letter verifying their company is the sole source distributor of the Loki MK2 manufactured by SKY-HERO.

I am seeking your approval to purchase the Loki MK2 tactical drone package from Aardvark Tactical for \$12,555.00. If you have any questions or concerns, please do not hesitate to contact me. In my absence you may also contact Deputy Chief Pilkington or Deputy Chief Yates. Thank you for your consideration of this request.

Sincerely,

A black rectangular redaction box covering the signature of the Chief of Police.

Chief of Police

Cc: Mayor Mike Troup
Mr. Jeff Mays, DAS
Ms. Sheri Ray, Comptroller
Ms. Mary Ann Ervin
Deputy Chief Pilkington

RESOLUTION

WHEREAS, the Quincy Police Department recognizes that the safety of our citizens and police officers is our top priority; and

WHEREAS, there is technology available today that was not available in the past that can significantly increase the safety of our officers assigned to handle dangerous situations; and

WHEREAS, the Quincy Police Department Emergency Response Team is tasked with handling dangerous critical incidents involving wanted suspects who are believed to be armed and in a position of advantage that makes the approach of law enforcement officers extremely hazardous; and

WHEREAS, the Loki MK2 Tactical Drone utilizes technology that allows police officers to visually and audibly search an area believed to be occupied by a suspect without exposing officers to the potential danger of manually searching for an armed suspect; and

WHEREAS, the Federal Bureau of Investigations Special Weapons and Tactics team, North Chicago, recently conducted a training evolution with the QPD ERT and strongly recommended the Loki MK2 as a must-have piece of safety equipment they own and deploy regularly; and

WHEREAS, the Quincy Police ERT purchased a tactical robot approximately 20 years ago that was used on several occasions to assist with similar searches, which recently stopped operating and repair is not feasible; and

WHEREAS, the Loki MK2 Tactical Drone is an ideal replacement for the tactical robot and utilizes the latest technology available to provide another level of safety for our citizens and officers; and

WHEREAS, Aardvark Tactical of La Verne, CA, is the sole source vendor for the Loki MK2 manufactured by SKY-HERO; and

THEREFORE BE IT RESOLVED, the Chief of Police and Police Aldermanic Committee recommend to the Mayor and City Council that the normal bidding process be waived and the Police Department be allowed to purchase a Loki MK2 tactical drone package from Aardvark Tactical of La Verne, CA, for the total cost of \$12,555.00.

Robert A. Copley
Chief of Police

March 7, 2022

Whistleblower Reporting and Anti-Retaliation Policy and Procedures

General Policy

It is the policy of the City of Quincy to act in accordance with Illinois Public Act 101-652 generally, and specifically Section 4.1 of the Public Officers Prohibited Activities Act (50 ILCS 105/4.1).

It is the policy of the City of Quincy to prohibit any official from retaliating against any employee who: (a) reports an improper governmental action, (b) cooperates in the investigation related to a report of an improper governmental action, or (c) testifies in a proceeding or prosecution of an improper governmental action. An improper governmental action is defined as follows.

“Improper governmental action” includes any action by a City of Quincy employee, an appointed member of a board, commission, or committee, or an elected official of the City of Quincy that is undertaken in violation of federal, State, or unit of local government law or rule; is an abuse of authority; violates the public’s trust or expectation of his or her conduct; is of substantial and specific danger to the public’s health or safety; or is a gross waste of public funds.

“Improper governmental action” does not include City of Quincy personnel actions, including, but not limited to employee grievances, complaints, appointments, promotions, transfers, assignments, reassignments, reinstatements, restorations, reemployment, performance evaluations, reductions in pay, dismissals, suspensions, demotions, reprimands, or violations of collective bargaining agreements, except to the extent the actions amounts to retaliation. Retaliation, in this context means retaliatory action that results from an employee’s protected activity of reporting improper governmental action, cooperating in the investigation, proceeding or prosecution of a reported improper governmental action.

Copies of this Policy and Procedure, along with a copy of Section 4.1 of the Public Officers Prohibited Activities Act will be given to every employee upon hiring. Additionally, these same documents will be furnished or made available to all employees on an annual basis.

Designation of Auditing Official

City of Quincy designates the Human Resource Manager, Corporation Counselor or their designee, or a designee of the Mayor, to serve as the Auditing Official of the City of Quincy, with the duties and responsibilities set forth in 50 ILCS 105/4.1. The Corporation Counselor and Human Resource Manager shall review any complaints brought under this policy and determine investigation procedure. The Human Resource Manage and Corporation Counsel will either investigate the complaint or assign the complain to another auditing official to complete the investigation.

Procedures for Reporting and Investigating Reports of Improper Governmental Action

A. Reporting an “Improper Governmental Action” or Retaliation.

1. To invoke the protections outlined in this Policy, if an employee believes that he/she has witnessed an improper governmental action, as defined in the Policy above, the employee must submit a written report of the improper governmental action to the Auditing Official.
2. If an employee believes that he/she has been retaliated against for reporting improper governmental action, or cooperating in the investigation, or procedure involving an improper governmental action, the employee must report such alleged retaliation to the Auditing Official within sixty (60) days of the retaliatory action taking place.
3. The Auditing Official may transfer the complaint to another auditing official, including the State’s Attorney, if he/she determines that it is appropriate.
4. If the Auditing Official is also the subject of the complaint, the Complainant may file the complaint with any State’s Attorney.

B. Investigation of Complaint.

1. Identity of the Complainant
 - a. The Auditing Official will keep the identity of the Complainant confidential to the extent allowed by law.
 - b. The Complainant may waive confidentiality in writing on a form presented to the Auditing Official.
2. The Auditing Official shall investigate the complaint promptly and thoroughly, and conclude whether or not the evidence gathered through such investigation warrants a finding that either an improper governmental action, or retaliation for filing such a complaint or complying with such investigation, occurred or did not occur.
3. The investigation by the Auditing Official may include:
 - a. Interviews of the Complainant;
 - b. Interviews of individuals who may have knowledge about the complaint or may be the subject of the complaint;
 - c. Inspection of documentation (in written, printed, or electronic format) relevant to the complaint;

- d. Take any other appropriate measures to ensure that the complaint has been thoroughly investigated.
- e. Make a determination whether the complaint has merit or whether the complaint does not have merit.

C. Determination and Remedial Action If Necessary.

1. If the Auditing Official determines that the complaint has no merit, he/she can dismiss the complaint.
2. If the Auditing Official determines that the complaint has merit, he/she may take remedial action on behalf of the Complainant, including reinstatement, reimbursement for lost wages or expenses, promotion, or other remedial action that the Auditing Official deems appropriate. The Auditing Official may also make his/her investigation findings available to the Complainant's attorney if the Auditing Official finds that restitution is not sufficient.
3. Any person who engages in prohibited retaliation under Section 4.1 of the Public Officers Prohibited Activities Act may also be subject to fines, appropriate employment action, civil or criminal prosecution, or any combination of these actions.

RESOLUTION NO. _____

A RESOLUTION ESTABLISHING A WHISTLEBLOWER REPORTING AND ANTI-RETALIATION POLICY FOR THE CITY OF QUINCY

WHEREAS, the City of Quincy (“City”) is an Illinois municipal corporation organized and operating pursuant to authority granted by the Constitution and Laws of the State of Illinois; and

WHEREAS, the Whistleblower Act (740 ILCS 174/1 et seq.) and Section 4.1 of the Public Officer Prohibited Activities Act, 50 ILCS 105/4.1, as added pursuant to Public Act 101-0652, prohibits units of local government from retaliating against whistleblowers; and

WHEREAS, the Retaliation Against Whistleblower Act, 50 ILCS 105/4.1 requires municipalities to develop an Anti-retaliation Policy and Procedures; and

WHEREAS, the state further requires that an “auditing official” be available to receive a report of retaliation; and

WHEREAS, the City Council desires to establish official City of Quincy Whistleblower Reporting and Anti-Retaliation Policy and Procedures, as attached hereto as Exhibit A, to prohibit retaliation against whistleblowers; and

WHEREAS, the City Council finds and determines that establishing the City of Quincy Whistleblower Reporting and Anti-Retaliation Policy and Procedures serves the best interests of the City, its officials, employees and City residents.

NOW, THEREFORE, BE IT HEREBY RESOLVED, BY THE CITY COUNCIL OF THE CITY OF QUINCY, IN ADAMS COUNTY, ILLINOIS, AS FOLLOWS:

SECTION 1: The foregoing recitals are incorporated into and made a part of this Resolution as findings of the City Council.

SECTION 2: The City Council hereby declares that the City of Quincy Whistleblower Reporting and Anti-Retaliation Policy and Procedures, attached hereto as Exhibit A, are hereby approved.

SECTION 3: If any section, paragraph, clause, or provision of this Resolution shall be held invalid, the invalidity thereof shall not affect any of the other provisions of this Resolution.

SECTION 4: All Resolutions in conflict herewith are hereby repealed to the extent of such conflict.

SECTION 5: This Resolution shall be in full force and effect from after its passage, approval and publication as provided by law.

PASSED this _____ day of _____, 2022, by the Corporate Authorities of the City of Quincy a roll call vote as follows:

AYES:

NAYS:

ABSTAIN:

ABSENT:

APPROVED

ATTEST:



**City of Quincy
Quincy Transit Lines**

**2020 Jennifer Road
Quincy IL 62301**
Marty Stegeman
Transportation Director

**217-228-4550
Fax: 217-228-4448**

Office: 217-228-4567

March 3, 2022

To: The Honorable Mayor Troup and
City Council members
From: Marty Stegeman
Transportation Director
All;

Included in this week's agenda you will find a resolution for the acceptance of a Capital Grant from IDOT.

Quincy Transit has been trying to get a grant to rehabilitate the old transit facility located at 1900 Seminary road. This is being done to allow for several issues that need to be addressed. Currently our office facility does not meet ADA standards for access to the public. There are several issues included in this; first the concrete leading to the facility does not meet the ADA slope requirement, second the door does not have an automated entry point, third there are no sidewalks from the nearest potential bus stop (18th & Seminary) to the current location. Relocating to the 1900 Seminary location will address these issues.

Additionally; we have for more than 10 years been trying to get an automated bus wash system. This grant will allow for us to accomplish this at the 1900 Seminary location as well. The benefits to the bus wash will be reduced water usage, as the system will recycle 95% of the water after it is used. Less soap will be used as well. Finally, we will cut the cleaning time on the exterior of the buses from 30 to 40 minutes per bus to around 6 minutes per bus.

The final portion of this grant will pay for the replacement of concrete at the Central Services / Transit garage facility at 2020 Jennifer road.

This grant award is for \$2.5 million and is 100% funded with no match from the City.

I am asking for your support in allowing us to accept the contract as it has been offered for the full amount of \$2.5 million.

Marty Stegeman
Transportation Director
2020 Jennifer Rd.
Quincy, IL 62301
217-228-4567

Resolution

Resolution authorizing application for a Public Transportation Capital Assistance Grant under the Illinois Department of Transportation’s general authority to make such Grants.

WHEREAS, The provision and improvement of public transportation facilities is essential to the development of a safe, efficient, functional public transportation system; and

WHEREAS, The Illinois Department of Transportation has the authority to make such Grants and makes funds available to offset certain capital costs of a private non-profit, general public transportation system or an IDOT Certified Public Provider transportation system providing specialized paratransit service; and

WHEREAS, Grants for said funds will impose certain obligations upon the recipient.

NOW, THEREFORE, BE IT RESOLVED BY THE GOVERNING BOARD OF City of Quincy:

Section 1. That an application be made to the Office of Intermodal Project Implementation (OIPI), Department of Transportation, State of Illinois, for a financial assistance grant under the Illinois Department of Transportation’s general authority to make such Grants, for the purpose of off-setting certain public transportation facility capital costs of City of Quincy.

Section 2. That Mayor of City of Quincy is hereby authorized and directed to execute and file on behalf of City of Quincy such application.

Section 3. That the Mayor of City of Quincy is authorized to furnish such additional information as may be required by the Office of Intermodal Project Implementation in connection with the aforesaid application for said Grant.

Section 4. That Mayor of City of Quincy is hereby authorized and directed to execute and file on behalf of City of Quincy all required Grant Agreements with the Illinois Department of Transportation.

PRESENT and ADOPTED the 7th day of March 2022

(Signature of Official)

ATTEST:

Mayor

Title

City Clerk

Title

RESOLUTION

WHEREAS, the City desires to finance improvements to its Combined Sewer Overflow System with a \$9 million loan through the Illinois Environmental Protection Agency's Water Pollution Control Loan Program; and,

WHEREAS, application provisions for loans from the Water Pollution Control Loan Program requires that the City of Quincy authorize a representative to sign the loan application and supporting documents; now,

THEREFORE BE IT RESOLVED, by the City Council of the City of Quincy that the Mayor is hereby authorized to sign all loan application forms and documents.

Resolved this 7th day of March, 2022.

Signature

Date

Printed Name

Title

Certified to be a true and accurate copy, passed and adopted on the above date.



Signature & Stamp/Seal of Notary Public

RESOLUTION

WHEREAS, in August of 2018 the Illinois Environmental Protection Agency approved the City of Quincy's Long Term Control Plan (LTCP) for the elimination of combined sewer overflow (CSO); and,

WHEREAS, the terms of the CSO LTCP requires that the design of Phase II construction improvements be completed by October 2022; and,

WHEREAS, the second phase of improvements includes the expansion of the Waste Water Treatment Plant pump station and structures to increase the plant's rated capacity from 78 mgd to 90 mgd; and,

WHEREAS, Crawford, Murphy and Tilly of Springfield, Illinois has submitted a proposal for an amount not to exceed \$330,000.00 for design and bidding services for this phase of the project; and,

WHEREAS, funding for service is available in the 2022/2023 Sewer Fund fiscal year budget.

NOW, THEREFORE IT BE RESOLVED, that the Director of Utilities and Engineering and Utilities Committee recommend to the Mayor and Quincy City Council that the proposal from Crawford, Murphy and Tilly of Springfield, Illinois for an amount not to exceed \$330,000.00 be accepted.

Jeffrey Conte , P.E.
Director of Utilities & Engineering

March 7, 2022

RESOLUTION

WHEREAS, the Department of Utilities requires the purchase of ten (10) 6 inch fire service assembly water meters for the replacement of aging commercial meters; and,

WHEREAS, Badger meters offered by Midwest Meter, Inc. offers the automatic meter reading technology that is compatible with the automatic meter reading system employed by the City of Quincy thus qualifying them as a sole source provider; and,

WHEREAS, the City has received an invoice from Midwest Meter, Inc. of Edinburg, Illinois totaling \$113,130.40 for the purchase of the water meters; and,

WHEREAS, funding for the water meters is available in the 2021/2022 Water Fund fiscal year budget.

NOW, THEREFORE BE IT RESOLVED, that the Director of Utilities and Engineering and Utilities Committee recommend to the Mayor and Quincy City Council that normal bidding requirements be waived and the invoice from Midwest Meter, Inc., of Edinburg, Illinois in the amount of \$113,130.40 be approved for payment.

Jeffrey Conte, P.E
Director of Utilities & Engineering

March 7, 2022



CITY OF QUINCY

Department of Utilities & Engineering

Steven E. Bange, P.E.
Senior Project Engineer
City Hall – 730 Maine Street
Quincy, Illinois 62301-4048
(217)228-7731

MEMORANDUM

To: City Council & Administration

RE: 3/7/2022 Council Meeting

Adams County / City of Quincy – 48th & State Agreement & Funding Resolution

Please find attached the agreement between the City & Adams County to proceed with the project to construct a single lane roundabout at South 48th & State and improve 600 ft. of State Street east of 48th and 1300 ft. of S. 48th south of State Street.

The agreement states that the City and County shall split the cost of the construction, land acquisition, utility relocations (other than the City's water). The City would be 100% responsible for the cost to relocate water valves and extend the City's water service to east along State Street to the end of the project. The engineering fee listed in Section 10 is for reimbursing the County for a portion of their cost to provide construction inspection and management.

With the approval of this agreement and funding resolution, the land acquisition process can begin. Once the property has been acquired, the project will go out for bid. Following the bid opening, the Council will have to concur with the lowest bid before a contract is signed with the contractor.

Construction plans are 99% completed and are being reviewed by IDOT.

The current construction cost estimate for the project is \$3.4 million. The approximate breakout of the costs is:

- \$ 128,000 48th Street north of State St.
Resurfacing & sidewalks
- \$1,110,000 48th Street south of State St.
Resurfacing, widening (2 lanes with wider shoulder), curb & gutter, sidewalk on the west side. Culvert repair & extension, storm sewers. This will be the first phase in widening 48th Street and adding sidewalk to JWCC / Harrison St.
- \$ 123,000 State Street west of 48th St.
Resurfacing & sidewalks
- \$ 314,000 State Street east of 48th St.
Resurfacing, widening (3 lanes), curb & gutter, & storm sewers.
- \$1,429,000 48th & State intersection (single lane roundabout)
New PCC pavement, curb & gutter, sidewalk, storm sewers, & lighting.
- \$ 340,000 Water main
Relocating check valves and extending the water main east on State St.

To date, minus the state grant for \$170,000, the City and County have spent \$113,222.00 on the project for design, appraisals, and environmental studies.



48th Street (north of State St.)
Work to include resurfacing & sidewalks.
48th Street to remain 4 lanes.
\$128,000

State Street (west of 48th St.)
Work to include resurfacing & sidewalks.
State St. to be restriped to add a center turn lane.
\$123,000

State Street (east of 48th St.)
Work to include widening to 3 lanes, curb & gutter, storm sewers,
and extension of the City's water main.
\$654,000

48th & State Intersection
Single-lane roundabout
PCC pavement, curb & gutter, sidewalks, storm sewers
and lighting.
\$1,429,000

48th Street (south of State St.)
Work to include widening (4' shoulders), curb & gutter, storm sewers,
sidewalk along the west side, and extension / repair of the 7' pipe culvert.
\$1,110,000



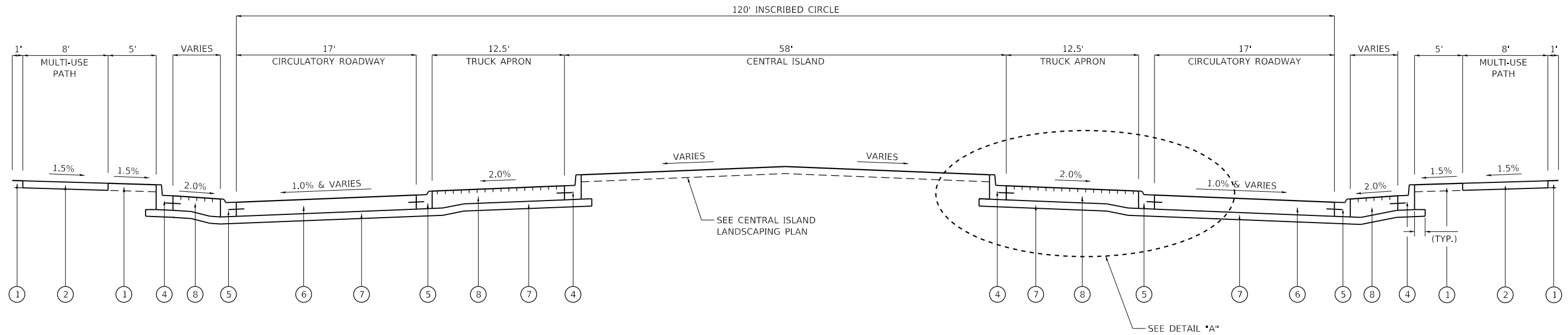

PROPOSED TYPICAL SECTION A-A

PROPOSED

- ① PROPOSED TOPSOIL PLACEMENT, 4"
- ② PROPOSED PCC SIDEWALK, 4"
- ④ PROPOSED COMBINATION CONCRETE CURB AND GUTTER, TYPE B-6.12
- ⑤ PROPOSED COMBINATION CONCRETE CURB AND GUTTER, TYPE M-2.12
- ⑥ PROPOSED PCC PAVEMENT, 9" (JOINTED)
- ⑦ PROPOSED SUB-BASE GRANULAR MATERIAL, TYPE A, 4"
- ⑧ PROPOSED PORTLAND CEMENT CONCRETE PAVEMENT, 9" (SPECIAL)

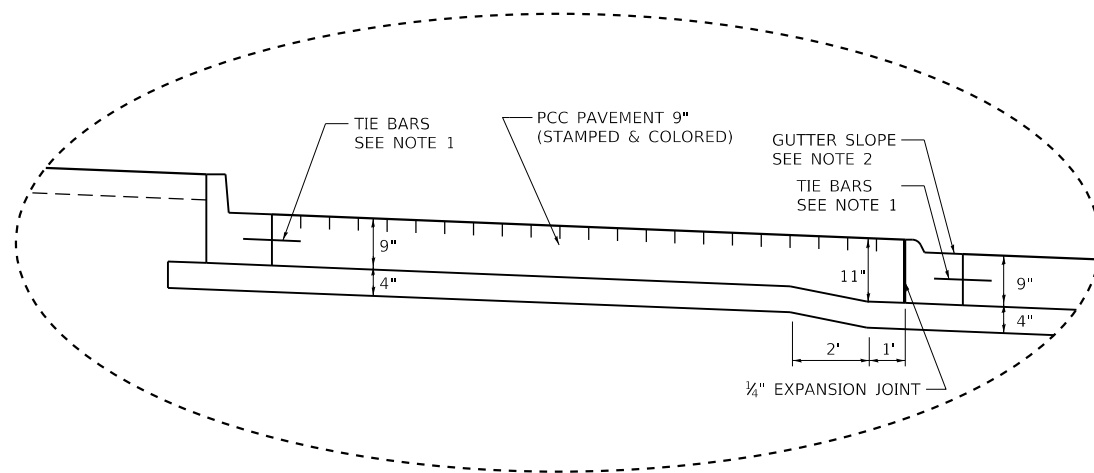

DETAIL "A"

NOTES:

1. TIE BARS IN ACCORDANCE WITH DETAILS FOR LONGITUDINAL CONSTRUCTION JOINT AS SHOWN ON STANDARD 420001-10. COST OF THE TIE BARS TO INCLUDED IN THE COST OF PCC PAVEMENT 9" (JOINTED)
2. TRUCK APRON GUTTER SLOPE SHALL BE CONSTRUCTED TO MATCH SLOPE OF ADJACENT PAVEMENT, SEE INTERSECTION DETAIL.

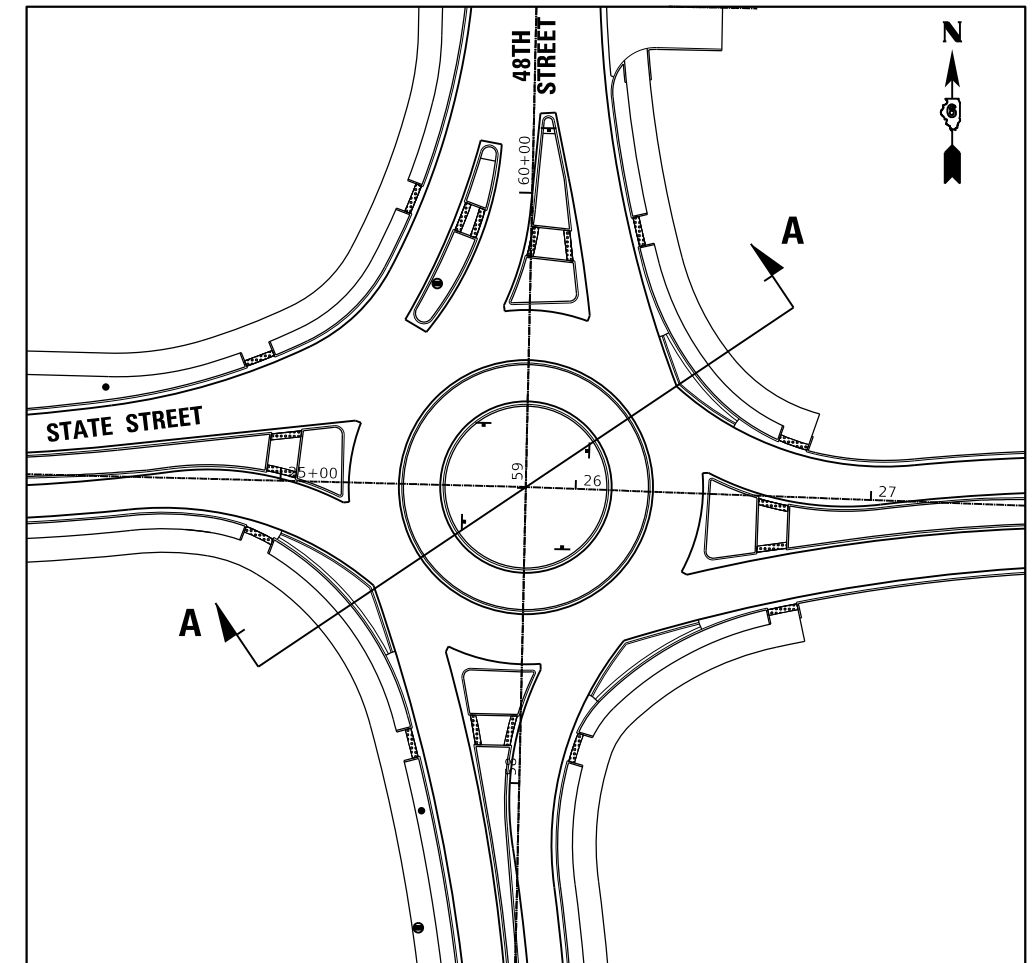

**ADAMS COUNTY
HIGHWAY DEPARTMENT**

**TYPICAL SECTIONS
48TH AND STATE STREET ROUNDABOUT**

SCALE: SHEET 7 OF 7 SHEETS STA. TO STA.

F.A.U. RTE.	SECTION	COUNTY	TOTAL SHEETS	SHEET NO.
7831	20-00079-05-PV	ADAMS	121	19
CONTRACT NO.				
ILLINOIS FED. AID PROJECT				

MODEL: Default
 FILE: \\msc1c1\coursy\190000203-000\Drawings\Roadway\CADD_Sheets\1015-48th-ST-Typical Sections 007.dgn
 License No. 184-000813 © copyright CMT, Inc.



USER NAME = Rob Heady
 PLOT SCALE = 10.0000 ' / in.
 PLOT DATE = 2/4/2022

DESIGNED -
 DRAWN - RAH
 CHECKED - KLT
 DATE - FEBRUARY 2022

REVISED -
 REVISED -
 REVISED -
 REVISED -

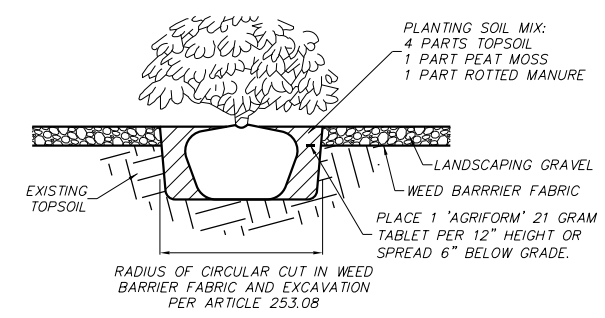
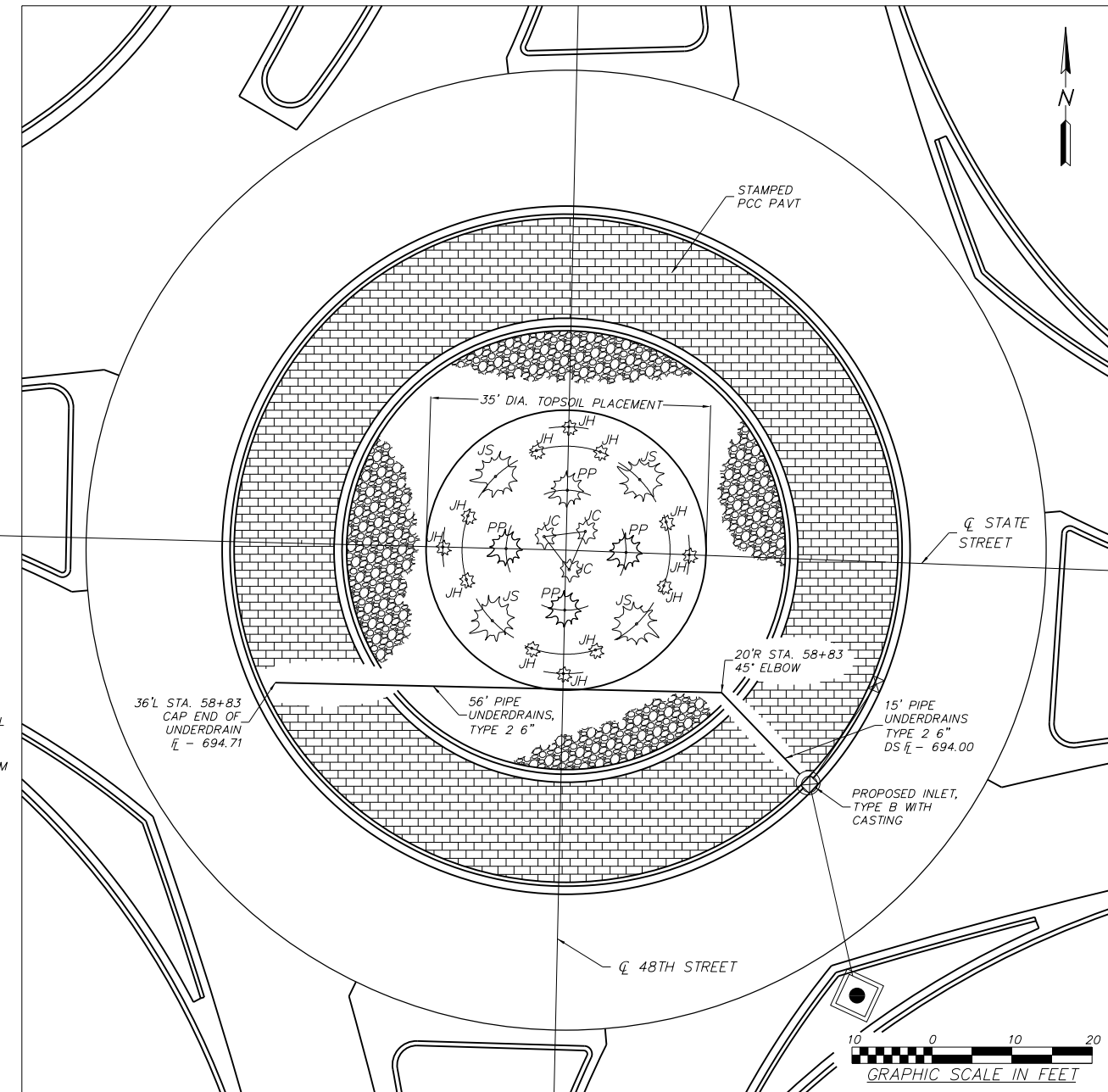
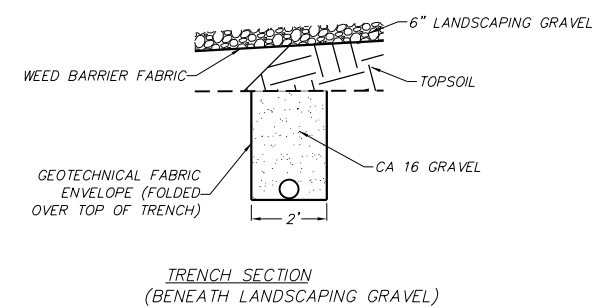
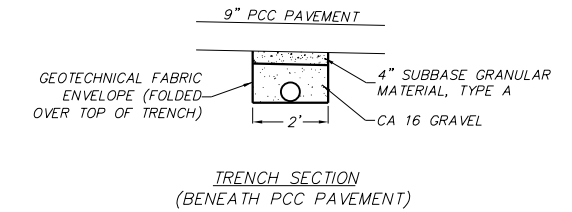
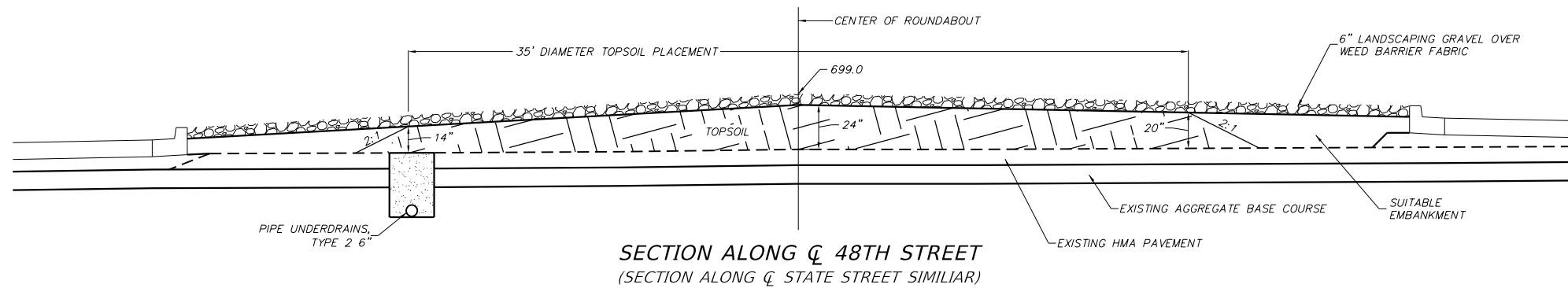

LANDSCAPING GRAVEL TO BE DISTRIBUTED AROUND THE PLANTING NO SOONER THAN 3 DAYS FOLLOWING THE PLANTING, INITIAL WATERING, AND PLACEMENT OF ADDITIONAL PLANTING SOIL DUE TO SETTLING.

EVERGREEN PLANTING DETAIL

LANDSCAPING QUANTITIES

ITEM	PAY QUANTITY	
TOPSOIL FURNISH AND PLACE, VARIABLE DEPTH	107 SQ YD	*EST. 65 CY
WEED BARRIER FABRIC	262 SQ YD	
LANDSCAPING GRAVEL	262 SQ YD	*EST. 30 TONS

* - PROVIDED FOR CONVENIENCE OF THE BIDDER, ACTUAL QUANTITY MAY VARY.

PLANTING LIST

MARK	COMMON NAME	BOTANICAL NAME	HEIGHT	SPREAD	QUANTITY	SPACING
JC	GOLD LACE JUNIPER	JUNIPERUS CHINENSIS 'GOLD LACE'	3' - 4'	5' - 6'	3	BEST FIT 5'-3" TRIANGULAR
JS	CALGARY CARPET JUNIPER	JUNIPERUS SABINE 'CALGARY'	9"	8' - 10'	4	12'-9" RADIUS ±9' L/R Q
JH	BLUE CHIP JUNIPER	JUNIPERUS HORIZONTALIS 'BLUE CHIP'	12"	6' - 8'	12	13' RADIUS ±4' L/R 15'-6" RADIUS ON Q
PP	DWARF GLOBE BLUE SPRUCE	PICEA PUNGENS 'GLOBOSA'	3' - 5'	5' - 6'	4	7'-6" RADIUS, ON Q

NOTES:

THE TOPSOIL AND LANDSCAPING GRAVEL SHALL BE PLACED BY THE CONTRACTOR IN A MANNER THAT PREVENTS EXCESSIVE COMPACTION OF THE TOPSOIL.

THE TOPSOIL SHALL BE LOAMY IN NATURE, FREE FROM HARD CLODS, STIFF CLAY, SOD, STONES, ROOTS, STICKS, AND OTHER DEBRIS OVER 1" IN SIZE. TOPSOIL SHALL BE FREE OF TOXIC MATERIALS AND SHALL HAVE A pH RANGE BETWEEN 5.5 AND 7.0.

THE SUITABLE EMBANKMENT SHALL CONSIST OF EITHER EARTH MATERIAL OR EXCESS AGGREGATE. THE EMBANKMENT SHALL BE FREE OF PIECES OF CONCRETE, HMA, OR ROCKS GREATER 4" IN ANY DIMENSION AND ANY OTHER TYPE OF CONSTRUCTION DEBRIS. THE MATERIAL SHALL BE COMPACTED TO ELIMINATE LARGE VOIDS AND TO LIMIT THE AMOUNT OF POST PLACEMENT SETTLEMENT.



MODEL: Default; FILE: \\msrc1\cadd\jrc\190000203-000\Drawings\Roadway\CADD_Sheets\1075-sh-1-landscaping\Evergreen.dwg; 006.dwg



USER NAME = Rob Heady	DESIGNED - JRF	REVISED -
PLOT SCALE = 20.0000 ' / in.	DRAWN - JRH	REVISED -
PLOT DATE = 2/4/2022	CHECKED - KLT	REVISED -
	DATE - FEBRUARY 2022	REVISED -

**ADAMS COUNTY
HIGHWAY DEPARTMENT**

**CENTRAL ISLAND LANDSCAPING PLAN
CH 5 - STATE STREET / CH37 - 48TH STREET**

SCALE: SHEET 6 OF 6 SHEETS STA. TO STA.

F.A.U. RTE.	SECTION	COUNTY	TOTAL SHEETS	SHEET NO.
7831	20-00079-05-PV	ADAMS	121	73
CONTRACT NO.				
ILLINOIS FED. AID PROJECT				

AGREEMENT

This agreement is entered into this _____ day of _____, 2022, by and between the COUNTY OF ADAMS of the State of Illinois, hereinafter called the COUNTY and the CITY OF QUINCY of the State of Illinois, hereinafter called the CITY.

WITNESSETH:

WHEREAS, the COUNTY in order to facilitate the free flow of traffic and ensure safety to the motoring public, is desirous of improving approximately 0.34 miles (1,800 feet) of South 48th Street, from 1,320 ft. south of State Street to 480 ft. north of State Street, and approximately 0.31 miles (1,655 ft.) of State Street, from 1,023 feet west of 48th Street to 632 ft. east of 48th Street. The improvement to include the construction of a PCC pavement roundabout, road widening and resurfacing, installation of storm sewers, sidewalk, roadway lighting and pavement markings, and the performance of all other work necessary to complete the project in accordance with the approved plans and specifications for Adams County Section 20-00079-05-PV.

WHEREAS, the CITY is desirous of said improvement at the intersection of North 48th Street and State Street in that same will be of immediate benefit to the motoring public and be permanent in nature; and is willing to participate in the project.

NOW, THEREFORE, in consideration of the mutual covenants contained herein, the parties hereto agree as follows:

1. The CITY, having obtained a Build Illinois Bond Fund grant for Phase I and Phase II design engineering services in the amount of \$170,000, selected the firm of Crawford, Murphy and Tilly (CMT) of Springfield, IL to provide those engineering services. The negotiated and agreed to amount for the engineering services is \$256,438.00.

The CITY to pay 50% and the COUNTY to pay 50% of the final cost of engineering services in excess of the \$170,000.00 grant amount.

2. Due to conditions presented in the Preliminary Environmental Site Assessment report, additional environmental consulting services are required. The CITY engaged the services of SCI Engineering, Inc for sampling and analytical testing of the soil at various locations within the project limits. The quoted fee for this work is \$7,000.00. The COUNTY agrees to reimburse the CITY for 50% of the final cost of the additional environmental consulting services provided.
3. The COUNTY and CITY shall exercise their respective franchise rights, if required, to cause private utilities to be relocated at no expense to either. Should it become necessary reimburse a utility company for the relocation of their facilities, the COUNTY to pay 50% and the CITY to pay 50% of the final cost of the relocation of each respective utility.
4. Due to the nature and complexity of the appraisal of right of way to be acquired for the project, the services of an IDOT Certified Appraiser are required. The COUNTY engaged the services of CMT as a contracting agent for said appraiser. The quoted fee for this work is \$19,784.00. The CITY agrees to reimburse the COUNTY for 50% of the final cost of the appraisal services provided.

5. Additional right of way and temporary construction easements are required for the construction of this project. It is the intent of both the COUNTY and the CITY to acquire all right of way by warranty deed including the existing dedicated right of way.

It is mutually agreed by and between the parties hereto that the estimated cost and proration for the acquisition of additional right of way and easements is as follows:

Land Acquisition	County	%	City	%
Additional Right of Way	\$36,100	50	\$36,100	50
Temporary Construction Easements	\$8,925	50	\$8,925	50
Existing Right-of-Way	\$409		\$81	
Total	\$45,434		\$45,106	

6. The COUNTY and CITY will jointly review and approve the plans and specifications prior to letting. The plans and specifications shall be prepared in accordance with the Bureau of Local Roads and Streets (BLRS) Manual, IDOT Standard Specifications and the Bureau of Design & Environment (BDE) Manual as appropriate.
7. The CITY agrees to provide written approval of that portion of the plans and specifications relative to the CITY's obligations described herein, prior to the COUNTY's advertising for the afore described proposed improvement, a copy of which is attached as Exhibit A.
8. The COUNTY agrees to advertise, receive bids, award, and sign the contract for project construction with concurrence of the CITY.
9. The COUNTY agrees to have their engineering representatives inspect the project work and certify that all is reasonably completed in accordance with the IDOT Specifications. Written certification shall be included with the final request for payment.
10. It is mutually agreed by and between the parties hereto that the estimated cost and cost proration for this improvement is as follows:

Type of Work	County		City	
	Cost	%	Cost	%
Construction	\$1,552,879.25	50	\$1,552,879.25	50
Water Main Relocation	-----		\$339,530	100
Engineering			\$56,772	3 ⁽¹⁾
Total	\$1,552,879.25		\$1,949,181.25	

(1) – Engineering fees applied to final cost of the CITY's prorated portion of project.

Participation and reimbursement shall be predicated by the percentages shown above for the specified type of work. Costs shall be determined by multiplying the final quantities by the contract unit prices.

11. The COUNTY will submit periodic invoices to the CITY for all work completed for reimbursement. The invoice shall include support documentation such as a pay estimate for the contractor.
12. Upon the completion of the contract work but prior to the final payment to the contractor, the COUNTY will schedule a final field inspection. The final inspection shall be at a time mutually agreed upon by the COUNTY and the CITY.
13. The prior maintenance responsibilities for sanitary sewer and water mains shall remain unchanged.
14. The COUNTY agrees to comply with all applicable Executive Orders and Federal Highway Acts pursuant to the Equal Employment Opportunity and non-discrimination regulations required by the Illinois Department of Transportation.
15. Under the penalties of perjury, the COUNTY certifies that 37-6000379 is its correct Federal Taxpayer Identification Number and it is doing business as a governmental entity.

This AGREEMENT and the covenants contained herein shall be null and void in the event a contract covering the construction work contemplated herein is not awarded within 6 months subsequent to execution of the agreement.

This agreement shall be binding upon and to the benefit of the parties hereto, their successors and assigns.

Attest

County Clerk
(SEAL)

By: _____
R. Kent Snider
Chairman, Adams County Board

Date: _____

Attest

City Clerk
(SEAL)

By: _____
Michael A. Troup
Mayor, City of Quincy

Date: _____

EXHIBIT A

FINAL PLAN APPROVAL

WHEREAS, ADAMS COUNTY and the CITY of QUINCY, have entered into an AGREEMENT for the improvement of approximately 0.34 miles (1,800 feet) of South 48th Street, from 1,320 ft. south of State Street to 480 ft. north of State Street, and approximately 0.31 miles (1,655 ft.) of State Street, from 1,023 feet west of 48th Street to 632 ft. east of 48th Street. The improvement to include the construction of a PCC pavement roundabout, road widening and resurfacing, installation of storm sewers, sidewalk, roadway lighting and pavement markings, and the performance of all other work necessary to complete the project in accordance with the approved plans and specifications for Adams County Section 20-00079-05-PV.

WHEREAS, in order to facilitate said improvement and in compliance with said AGREEMENT, the CITY hereby gives written approval of that portion of the plans and specifications relative to the CITY's financial and maintenance obligations.

FINAL PLANS APPROVED this _____ day of _____, 2022.

By: _____
Jeffrey Conte, P.E.
Director of Utilities & Engineering

Date: _____

COUNTY
CERTIFICATE

STATE OF ILLINOIS)
)SS
COUNTY OF ADAMS)

I, Ryan A. Niekamp, County Clerk, in and for ADAMS COUNTY of the State of Illinois, hereby certify that R. Kent Snider, Chairman of the Adams County Board, was duly authorized to execute the foregoing Agreement on behalf of the County Board of Adams County, pursuant to a resolution adopted by the County Board at a meeting on _____, 2022.

IN TESTIMONY WHEREOF, I have hereunto set my hand and seal this _____ day of _____, 2022.

County Clerk

(SEAL)

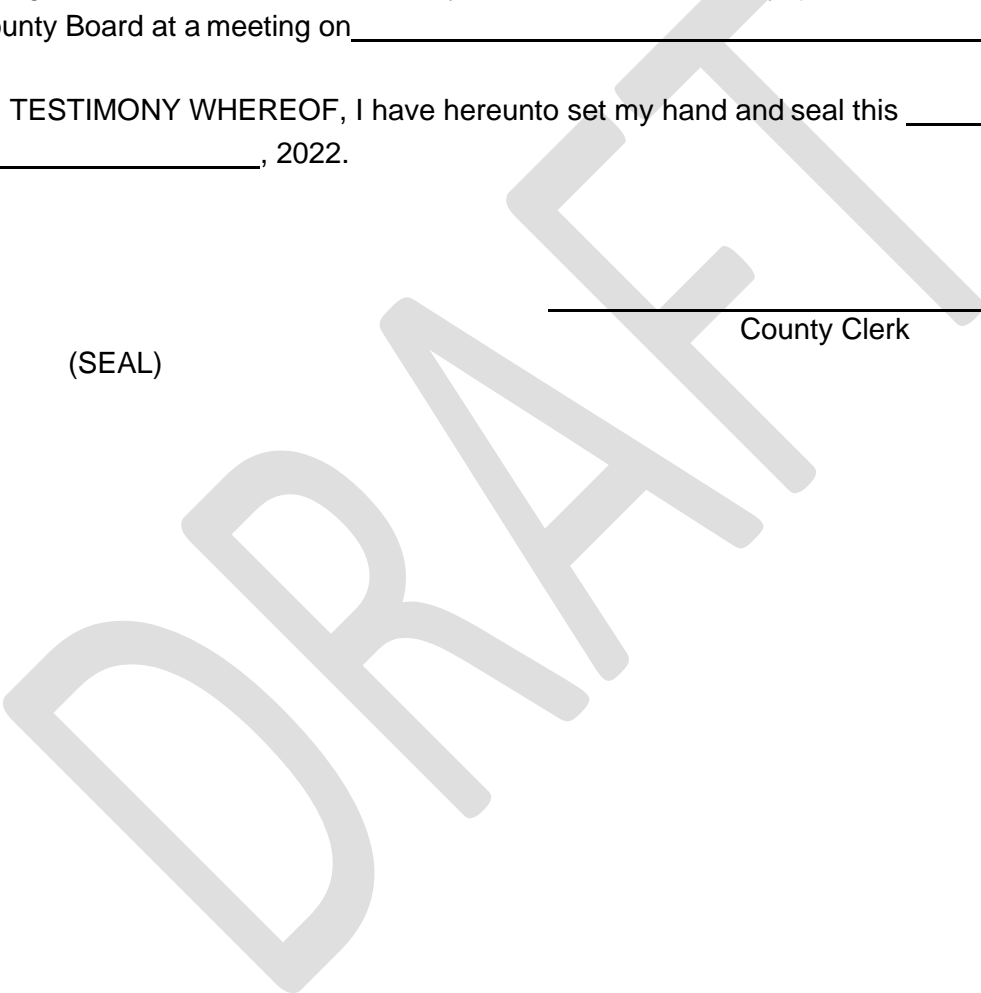

CITY
CERTIFICATE

STATE OF ILLINOIS)
)SS
COUNTY OF ADAMS)

I, Laura Oakman, City Clerk, in and for the CITY of QUINCY of the State of Illinois, hereby certify that Michael A. Troup, Mayor, was duly authorized to execute the foregoing Agreement on behalf of the City of Quincy, pursuant to a resolution adopted by the City Council at a meeting on _____, 2022.

IN TESTIMONY WHEREOF, I have hereunto set my hand and seal this _____ day of _____, 2022.

City Clerk

(SEAL)

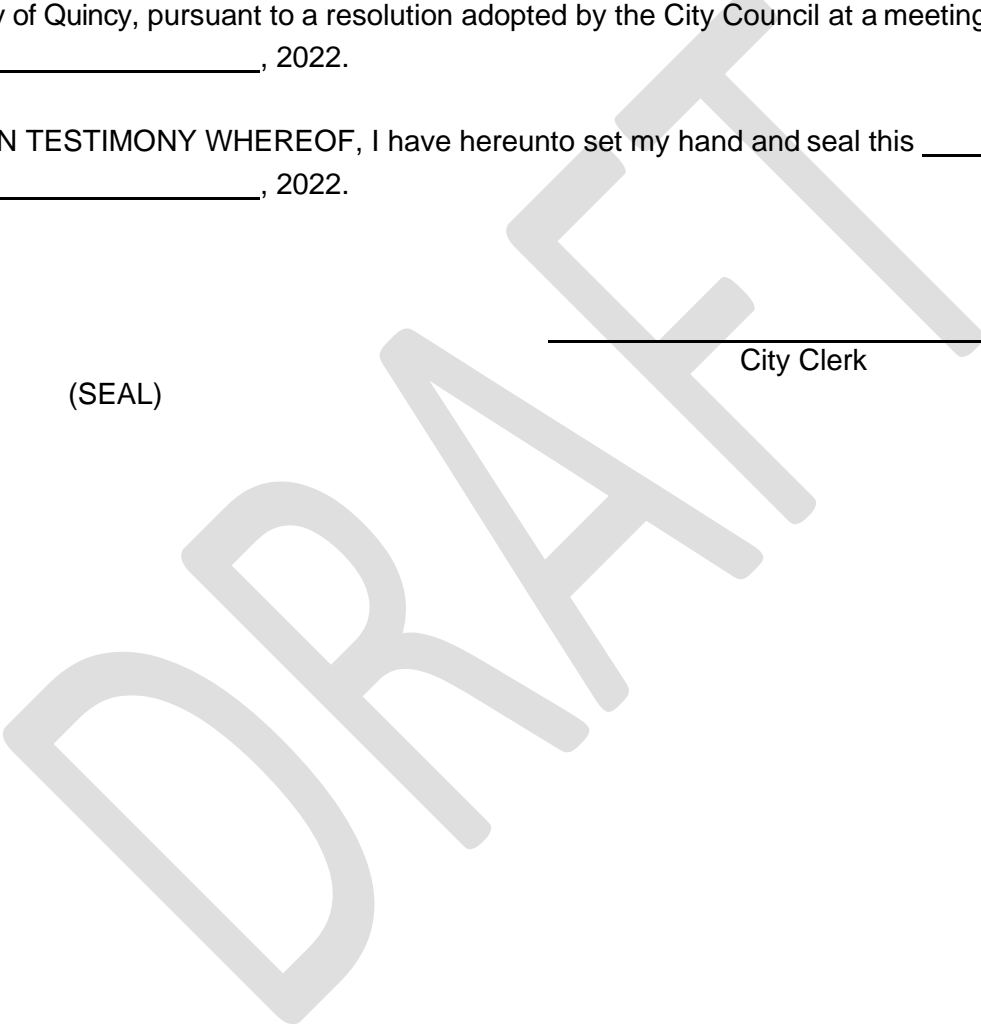

Steve Bange

From: James Frankenhoff <jamesfrankenhoff@co.adams.il.us>
Sent: Wednesday, February 23, 2022 4:53 PM
To: Steve Bange
Subject: [EXTERNAL]FW: EXTERNAL:RE: EXTERNAL:48th & State High Pressure Relocate

CAUTION: This email originated from outside your organization. Exercise caution when opening attachments or clicking links, especially from unknown senders.

Cost for gas main relocate.

From: Sutter, Zachary <ZSutter@ameren.com>
Sent: Thursday, September 09, 2021 3:25 PM
To: James Frankenhoff <jamesfrankenhoff@co.adams.il.us>
Cc: Snyder, Quinton E <QSnyder@ameren.com>
Subject: EXTERNAL:RE: EXTERNAL:48th & State High Pressure Relocate

CAUTION: This email originated from outside of the organization. Do not click links or open attachments unless you recognize the sender and know the content is safe.

Jim,

The estimate to relocate our 4" high pressure line for this project is \$48,711.49. We can go ahead and send that bill to you prior to construction or we can wait until after construction. If you want to wait until after construction, the actual job cost would be billed which could be a little bit lower or higher than the estimate. Would you like to pay this bill in advance based on the estimate or pay this bill after construction based off actual cost?

We are planning on the 1st quarter of 2022 for relocating our high pressure.

Let me know if you have any questions.

Thanks,

Zach Sutter :: Career Gas Engineer :: T 217.221.0813
Ameren Illinois :: 700 Jersey Street :: Quincy, IL 62301

From: James Frankenhoff <jamesfrankenhoff@co.adams.il.us>
Sent: Wednesday, August 18, 2021 8:22 AM
To: Sutter, Zachary <ZSutter@ameren.com>
Cc: Steve Bange <sbange@quincyl.gov>
Subject: [EXTERNAL] RE: EXTERNAL:48th & State High Pressure Relocate

EXTERNAL SENDER STOP.THINK.QUESTION.

Verify unexpected requests before opening links or attachments.

I guess set it up to bill this office.

RESOLUTION

WHEREAS, the City of Quincy strives to invest in the improvement of its infrastructure in order to facilitate the free flow of traffic and insure the safety of its pedestrian and motoring traffic; and,

WHEREAS, the City of Quincy and County of Adams desire to improve the intersection of 48th and State Streets; and,

WHEREAS, the proposed project will include the purchase of right-of-way, construction of a PCC pavement roundabout, road widening and resurfacing, installation of storm sewers, sidewalk, roadway lighting and pavement markings, and other construction related items; and,

WHEREAS, the County has pledged to commit funding for improvements to the sections of roadway that are under its jurisdiction; and,

WHEREAS, the County desires that the City enter into a joint agreement stating the City of Quincy will be responsible for a portion of the project cost for improvements made to the sections of roadway under the City's jurisdiction; and,

WHEREAS, the City's share of the proposed improvement project is estimated to be \$2,000,000.00; and,

WHEREAS, funding for the proposed project will be available in the 2022/2023 2019B GO Bond Street Project Fund fiscal year budget.

NOW, THEREFORE BE IT RESOLVED, that the Director of Utilities and Engineering and Central Services Committee present to the Mayor and Quincy City Council the proposed agreement between the City of Quincy and County of Adams, and that the Mayor be authorized to execute the Agreement on behalf of the City of Quincy if approved by the City Council. Said Agreement is attached hereto.

Jeffrey Conte, P.E.
Director of Utilities & Engineering

March 7, 2022

Approved this _____ day of March, 2022.

Laura Oakman, City Clerk

Michael Troup, Mayor

AGREEMENT

This agreement is entered into this _____ day of _____, 2022, by and between the COUNTY OF ADAMS of the State of Illinois, hereinafter called the COUNTY and the CITY OF QUINCY of the State of Illinois, hereinafter called the CITY.

WITNESSETH:

WHEREAS, the COUNTY in order to facilitate the free flow of traffic and ensure safety to the motoring public, is desirous of improving approximately 0.334 miles (1,764.5 feet) of South 48th Street, from 1,285 ft. south of State Street to 479.5 ft. north of State Street, and approximately 0.320 miles (1,690 ft.) of State Street, from 1,023 feet west of 48th Street to 667 ft. east of 48th Street. The improvement to include the construction of a PCC pavement roundabout, road widening and resurfacing, installation of storm sewers, sidewalk, roadway lighting and pavement markings, and the performance of all other work necessary to complete the project in accordance with the approved plans and specifications for Adams County Section 20-00079-05-PV.

WHEREAS, the CITY is desirous of said improvement at the intersection of South 48th Street and State Street in that same will be of immediate benefit to the motoring public and be permanent in nature; and is willing to participate in the project.

NOW, THEREFORE, in consideration of the mutual covenants contained herein, the parties hereto agree as follows:

1. The CITY, having obtained a Build Illinois Bond Fund grant for Phase I and Phase II design engineering services in the amount of \$170,000, selected the firm of Crawford, Murphy and Tilly (CMT) of Springfield, IL to provide those engineering services. The negotiated and agreed to amount for the engineering services is \$256,438.00.

The CITY to pay 50% and the COUNTY to pay 50% of the final cost of engineering services in excess of the \$170,000.00 grant amount.

2. Due to conditions presented in the Preliminary Environmental Site Assessment report, additional environmental consulting services are required. The CITY engaged the services of SCI Engineering, Inc for sampling and analytical testing of the soil at various locations within the project limits. The quoted fee for this work is \$7,000.00. The COUNTY agrees to reimburse the CITY for 50% of the final cost of the additional environmental consulting services provided.
3. The COUNTY and CITY shall exercise their respective franchise rights, if required, to cause private utilities to be relocated at no expense to either. Should it become necessary reimburse a utility company for the relocation of their facilities, the COUNTY to pay 50% and the CITY to pay 50% of the final cost of the relocation of each respective utility.
4. Due to the nature and complexity of the appraisal of right of way to be acquired for the project, the services of an IDOT Certified Appraiser are required. The COUNTY engaged the services of CMT as a contracting agent for said appraiser. The quoted fee for this work is \$19,784.00. The CITY agrees to reimburse the COUNTY for 50% of the final cost of the appraisal services provided.

- Additional right of way and temporary construction easements are required for the construction of this project. It is the intent of both the COUNTY and the CITY to acquire all right of way by warranty deed including the existing dedicated right of way.

It is mutually agreed by and between the parties hereto that the estimated cost and proration for the acquisition of additional right of way and easements is as follows:

Land Acquisition	County	%	City	%
Additional Right of Way	\$36,100	50	\$36,100	50
Temporary Construction Easements	\$8,925	50	\$8,925	50
Existing Right-of-Way	\$409		\$81	
Total	\$45,434		\$45,106	

- The COUNTY and CITY will jointly review and approve the plans and specifications prior to letting. The plans and specifications shall be prepared in accordance with the Bureau of Local Roads and Streets (BLRS) Manual, IDOT Standard Specifications and the Bureau of Design & Environment (BDE) Manual as appropriate.
- The CITY agrees to provide written approval of that portion of the plans and specifications relative to the CITY's obligations described herein, prior to the COUNTY's advertising for the afore described proposed improvement, a copy of which is attached as Exhibit A.
- The COUNTY agrees to advertise, receive bids, award, and sign the contract for project construction with concurrence of the CITY.
- The COUNTY agrees to have their engineering representatives inspect the project work and certify that all is reasonably completed in accordance with the IDOT Specifications. Written certification shall be included with the final request for payment.
- It is mutually agreed by and between the parties hereto that the estimated cost and cost proration for this improvement is as follows:

Type of Work	County		City	
	Cost	%	Cost	%
Construction	\$1,552,879.25	50	\$1,552,879.25	50
Water Main Relocation	----		\$339,530	100
Engineering			\$56,772	3 ⁽¹⁾
Total	\$1,552,879.25		\$1,949,181.25	

(1) – Engineering fees applied to final cost of the CITY's prorated portion of project.

Participation and reimbursement shall be predicated by the percentages shown above for the specified type of work. Costs shall be determined by multiplying the final quantities by the contract unit prices.

11. The COUNTY will submit periodic invoices to the CITY for all work completed for reimbursement. The invoice shall include support documentation such as a pay estimate for the contractor.
12. Upon the completion of the contract work but prior to the final payment to the contractor, the COUNTY will schedule a final field inspection. The final inspection shall be at a time mutually agreed upon by the COUNTY and the CITY.
13. The prior maintenance responsibilities for sanitary sewer and water mains shall remain unchanged.
14. The COUNTY agrees to comply with all applicable Executive Orders and Federal Highway Acts pursuant to the Equal Employment Opportunity and non-discrimination regulations required by the Illinois Department of Transportation.
15. Under the penalties of perjury, the COUNTY certifies that 37-6000379 is its correct Federal Taxpayer Identification Number and it is doing business as a governmental entity.

DRAFT

This AGREEMENT and the covenants contained herein shall be null and void in the event a contract covering the construction work contemplated herein is not awarded within 6 months subsequent to execution of the agreement.

This agreement shall be binding upon and to the benefit of the parties hereto, their successors and assigns.

Attest

County Clerk
(SEAL)

By: _____
R. Kent Snider
Chairman, Adams County Board

Date: _____

Attest

City Clerk
(SEAL)

By: _____
Michael A. Troup
Mayor, City of Quincy

Date: _____

EXHIBIT A

FINAL PLAN APPROVAL

WHEREAS, ADAMS COUNTY and the CITY of QUINCY, have entered into an AGREEMENT for the improvement of approximately 0.334 miles (1,764.5 feet) of South 48th Street, from 1,285 ft. south of State Street to 479.5 ft. north of State Street, and approximately 0.320 miles (1,690 ft.) of State Street, from 1,023 feet west of 48th Street to 667 ft. east of 48th Street. The improvement to include the construction of a PCC pavement roundabout, road widening and resurfacing, installation of storm sewers, sidewalk, roadway lighting and pavement markings, and the performance of all other work necessary to complete the project in accordance with the approved plans and specifications for Adams County Section 20-00079-05-PV.

WHEREAS, in order to facilitate said improvement and in compliance with said AGREEMENT, the CITY hereby gives written approval of that portion of the plans and specifications relative to the CITY's financial and maintenance obligations.

FINAL PLANS APPROVED this _____ day of _____, 2022.

By: _____
Jeffrey Conte, P.E.
Director of Utilities & Engineering

Date: _____

COUNTY
CERTIFICATE

STATE OF ILLINOIS)
)SS
COUNTY OF ADAMS)

I, Ryan A. Niekamp, County Clerk, in and for ADAMS COUNTY of the State of Illinois, hereby certify that R. Kent Snider, Chairman of the Adams County Board, was duly authorized to execute the foregoing Agreement on behalf of the County Board of Adams County, pursuant to a resolution adopted by the County Board at a meeting on _____, 2022.

IN TESTIMONY WHEREOF, I have hereunto set my hand and seal this _____ day of _____, 2022.

County Clerk

(SEAL)

DRAFT

CITY
CERTIFICATE

STATE OF ILLINOIS)
)SS
COUNTY OF ADAMS)

I, Laura Oakman, City Clerk, in and for the CITY of QUINCY of the State of Illinois, hereby certify that Michael A. Troup, Mayor, was duly authorized to execute the foregoing Agreement on behalf of the City of Quincy, pursuant to a resolution adopted by the City Council at a meeting on _____, 2022.

IN TESTIMONY WHEREOF, I have hereunto set my hand and seal this _____ day of _____, 2022.

City Clerk

(SEAL)

DRAFT

RESOLUTION

WHEREAS, the City of Quincy strives to invest in the improvement of its infrastructure in order to facilitate the free flow of traffic and insure the safety of its pedestrian and motoring traffic; and,

WHEREAS, the City of Quincy and County of Adams desire to improve the intersection of 48th and State Streets; and,

WHEREAS, the proposed project will include the purchase of right-of-way and the relocation of a natural gas main; and,

WHEREAS, the estimated cost for right-of-way purchases based on current appraisals is \$45,106.00 and the estimated cost for the gas main relocation is \$24,356.00; and,

WHEREAS, the City of Quincy will reimburse the County of Adams for fifty percent (50%) of costs associated with the right-of-way purchases and gas main relocation; and,

WHEREAS, to allow for the uninterrupted progression of the project in the event that changes or modifications are required, an additional 10% over the estimated cost shall be included in the encumbrance for this project; and,

WHEREAS, funding for the proposed project will be available in the 2022/2023 2019B GO Bond Street Project Fund fiscal year budget.

NOW, THEREFORE BE IT RESOLVED, that the Director of Utilities and Engineering and Central Services Committee present to the Mayor and Quincy City Council a request for the appropriation of \$69,462.00 for the purchase of right-of-way and relocation of a natural gas main for the proposed 48th and State Street intersection improvements.

Jeffrey Conte, P.E.
Director of Utilities & Engineering

March 7, 2022



CITY OF QUINCY

Department of Utilities & Engineering

Steven E. Bange, P.E.
Senior Project Engineer
City Hall – 730 Maine Street
Quincy, Illinois 62301-4048
(217)228-7731

MEMORANDUM

To: City Council & Administration

RE: 3/7/2022 Council Meeting

Harrison Street Bridge over Curtis Creek

The recent inspection of the bridge carrying Harrison Street over Curtis Creek (east of 24th Street) found 2 of the concrete box beams on the south side of the bridge are in poor condition. The pace of the deterioration has increased since the prior inspection. The structural engineer is recommending major rehabilitation or replacement of the bridge in the next couple of years.

In addition, the width of the bridge and sidewalk is not up to current design standards.

The resolution before Council, allocates \$520,000 of REBUILD Illinois bond funds for the project. The funds come from bond sales by the State which is an addition to our typical MFT funds. To date, the City has received, \$1,785,249.72 and is scheduled to receive another \$892,625 this year. We expect to allocate the majority of this \$892,625 towards this project once the money is received from IDOT and we have a better idea of the project scope. To date, \$1,265,000 of the REBUILD IL funds were allocated for the reconstruction of North 16th between Locust & Seminary Rd.

Following the allocation of the \$520,000, the City will have to hire a structural engineer to further evaluate our options for the bridge and design the new structure.

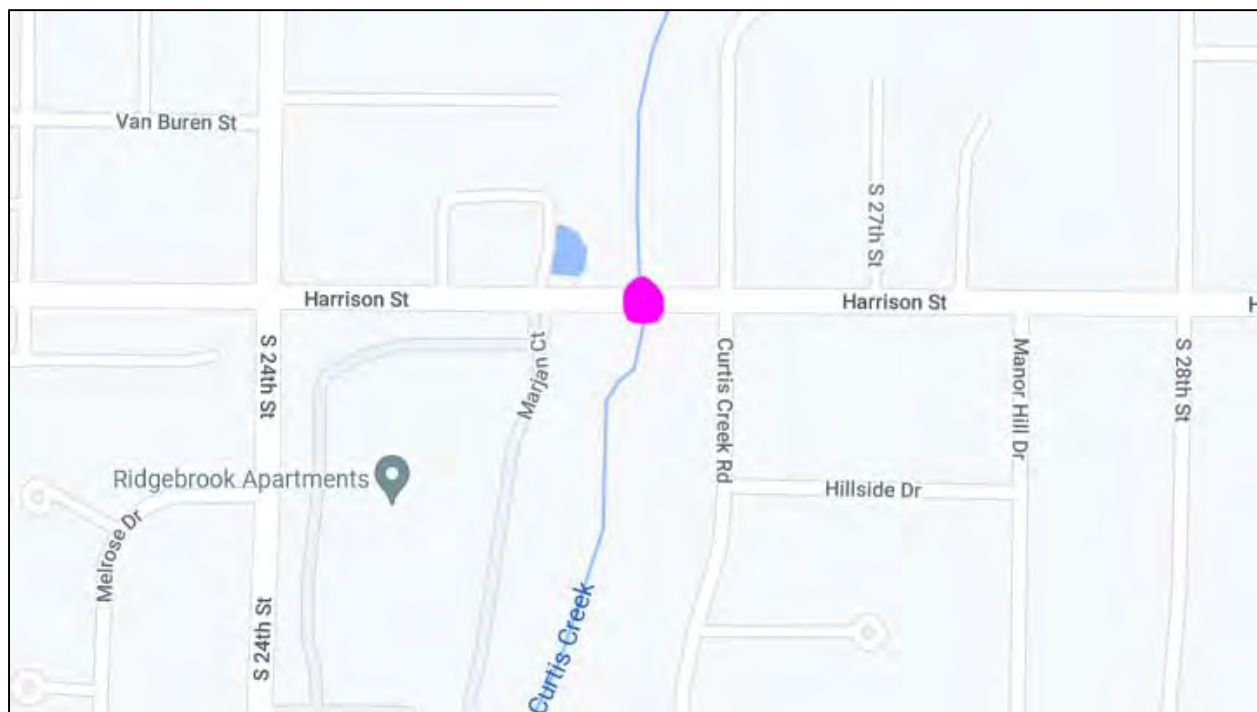





Photo No. 1
2/16/2022 Looking east at midspan of south exterior beams



Photo No. 2
2/16/2022 Looking west at 1/3 span of south exterior beams



Photo No. 3
2/16/2022 Looking at 4 prestressed strands on south exterior beam 1/3 span



Photo No. 4
2/18/2022 Looking east along south exterior beams at mid-span



Resolution for Improvement Under the Illinois Highway Code



Is this project a bondable capital improvement?

Yes No

Resolution Type	Resolution Number	Section Number
Original		22-00341-00-BR

BE IT RESOLVED, by the Council Governing Body Type of the City Local Public Agency Type
of Quincy Name of Local Public Agency Illinois that the following described street(s)/road(s)/structure be improved under
the Illinois Highway Code. Work shall be done by Contract Contract or Day Labor.

For Roadway/Street Improvements:

Name of Street(s)/Road(s)	Length (miles)	Route	From	To

For Structures:

Name of Street(s)/Road(s)	Existing Structure No.	Route	Location	Feature Crossed
Harrison	001-6005	FAU7814	700 ft east of 24th St	Curtis Creek

BE IT FURTHER RESOLVED,

1. That the proposed improvement shall consist of

Replacement of SN 001-6005 and associated street improvements.
Project to be funded with REBUILD Illinois bond funds.

2. That there is hereby appropriated the sum of five hundred twenty thousand
Dollars (\$520,000.00) for the improvement of
said section from the Local Public Agency's allotment of Motor Fuel Tax funds.

BE IT FURTHER RESOLVED, that the Clerk is hereby directed to transmit four (4) certified originals of this resolution to the district office of the Department of Transportation.

I, Laura Oakman Name of Clerk City Local Public Agency Type Clerk in and for said City Local Public Agency Type

of Quincy Name of Local Public Agency in the State aforesaid, and keeper of the records and files thereof, as provided by

statute, do hereby certify the foregoing to be a true, perfect and complete original of a resolution adopted by
Council Governing Body Type of Quincy Name of Local Public Agency at a meeting held on March 07, 2022 Date.

IN TESTIMONY WHEREOF, I have hereunto set my hand and seal this _____ day of _____ .
Day Month, Year

(SEAL)

Clerk Signature	Date

Approved

Regional Engineer Department of Transportation	Date



City of Quincy
Department of Utilities & Engineering

To: Mayor and City Council Members
Cc: Laura Oakman
From: Jeffrey Conte, Director of Utilities & Engineering
Date: March 7, 2022
Subject: IDOT Resolution for the Appropriation of REBUILD Illinois Funds

Mayor, City Council Members,

Please review the attached Illinois Department of Transportation (IDOT) Resolution for Improvement Under the Illinois Highway Code requesting to appropriate \$520,000.00 of REBUILD Illinois bond funds to the City of Quincy for the 2022/2023 Fiscal Year. This funding will be used for the replacement of the Harrison Street bridge (east of 24th Street) that crosses Curtis Creek.

The Director of Utilities and Engineering and Central Services Committee recommend approval of this IDOT Resolution.

Thank you for your consideration. If you have any questions, please let me know.



Resolution for Improvement Under the Illinois Highway Code



Is this project a bondable capital improvement?
[X] Yes [] No

Resolution Type: Original, Resolution Number, Section Number: 22-00341-00-BR

BE IT RESOLVED, by the Council of the City of Quincy, Illinois that the following described street(s)/road(s)/structure be improved under the Illinois Highway Code. Work shall be done by Contract

For Roadway/Street Improvements:

Table with 5 columns: Name of Street(s)/Road(s), Length (miles), Route, From, To

For Structures:

Table with 5 columns: Name of Street(s)/Road(s), Existing Structure No., Route, Location, Feature Crossed

BE IT FURTHER RESOLVED,

1. That the proposed improvement shall consist of Replacement of SN 001-6005 and associated street improvements. Project to be funded with REBUILD Illinois bond funds.

2. That there is hereby appropriated the sum of five hundred twenty thousand Dollars (\$520,000.00) for the improvement of said section from the Local Public Agency's allotment of Motor Fuel Tax funds.

BE IT FURTHER RESOLVED, that the Clerk is hereby directed to transmit four (4) certified originals of this resolution to the district office of the Department of Transportation.

I, Laura Oakman, Clerk in and for said City of Quincy, do hereby certify the foregoing to be a true, perfect and complete original of a resolution adopted by Council of Quincy at a meeting held on March 07, 2022

IN TESTIMONY WHEREOF, I have hereunto set my hand and seal this day of Month, Year

(SEAL)

Clerk Signature and Date fields

Approved

Regional Engineer Signature and Date fields



CITY OF QUINCY
DEPARTMENT OF PLANNING AND DEVELOPMENT

CITY HALL ANNEX, THIRD FLOOR, 706 MAINE STREET
QUINCY, ILLINOIS 62301
217-228-4515
FAX 217-221-2288

m e m o r a n d u m

TO: Hon. Mayor Troup and Members of City Council
FROM: Michael Seaver, Director of Inspection and Enforcement
DATE: 4. March. 2022
RE: Acceptance of Deed and Demolition of 426 College Ave.

On November 8, 2021, the west wall of the single-family dwelling located at 426 College Ave. partially collapsed into the adjacent public alley. Central Services crews immediately barricaded the alley, which has remained closed since that time.

The day following the collapse, I contacted the owner of the property about the likely need to demolish the structure. The owner indicated that she did not object to the demolition, but lacked the financial capacity to bear the cost. She has since provided our office with a statement of financial position, which supports her above assertion.

A quick search of the title shows no liens, mortgages, or other encumbrances.

Assistant Corporation Counsel Bruce Alford has prepared a Quit Claim Deed, which, once recorded, will convey the property to the City. Upon acceptance of the Deed, Central Services Director Kevin McClean has agreed to have City crews perform the demolition and cleanup.

I would respectfully request that Council accept the deed, which will provide the most expedient approach to demolishing the structure and abating the hazard that the structure represents. Please contact me if you have any questions or concerns.

RESOLUTION

WHEREAS, the City of Quincy has been taking enforcement action against 426 College, Quincy, Illinois, regarding minimum housing issues; and,

WHEREAS, the owner of the property has stated they do not have sufficient funds to maintain or repair the property; and,

WHEREAS, the owner of the property is willing to Quit Claim their interest in the property to the City of Quincy; and,

WHEREAS, by accepting the property by Quit Claim Deed will allow the City to demolish the structure, removing a dangerous and unsafe structure from the neighborhood, without the additional action of a fix or flatten case; and

WHEREAS, the City of Quincy can demolish the structure with the use of City of Quincy personnel.

NOW, THEREFORE, BE IT HEREBY RESOLVED by the Mayor and City Council that the City of Quincy may accept a Quit Claim Deed from the owner of the property commonly known as 426 College, Quincy, Illinois for said real estate.

Dated

Mayor

Dated

Clerk

RESOLUTION

WHEREAS, the City of Quincy has been taking enforcement action against 426 College, Quincy, Illinois, regarding minimum housing issues; and,

WHEREAS, the owner of the property has stated they do not have sufficient funds to maintain or repair the property; and,

WHEREAS, the owner of the property is willing to Quit Claim their interest in the property to the City of Quincy; and,

WHEREAS, by accepting the property by Quit Claim Deed will allow the City to demolish the structure, removing a dangerous and unsafe structure from the neighborhood, without the additional action of a fix or flatten case; and

WHEREAS, the City of Quincy can demolish the structure with the use of City of Quincy personnel.

NOW, THEREFORE, BE IT HEREBY RESOLVED by the Mayor and City Council that the City of Quincy may accept a Quit Claim Deed from the owner of the property commonly known as 426 College, Quincy, Illinois for said real estate.

Dated

Mayor

Dated

Clerk

CITY OF QUINCY

DEPARTMENT OF PLANNING & DEVELOPMENT

706 Maine Street | Third Floor | Quincy, IL 62301

Office: 217-228-4515 | Fax: 217-221-2288



MEMORANDUM

TO: Mayor and City Council

FROM: Sheri Reller

DATE: March 4, 2022

SUBJECT: IHDA Abandoned Residential Property Municipality Relief Program (APP) Grant

The city of Quincy accepted the Abandoned Residential Property Municipality Relief Program (APP) Grant from the Illinois Housing Development Authority (IHDA) on August 6, 2021, in the amount of \$50,000. However, the Supreme Court of Illinois issued an opinion on June 17, 2021, ruling that the APP's statutory framework is unconstitutional; therefore, IHDA can no longer operate the Abandoned Residential Property Municipality Relief Program due to Court's ruling. As a result, IHDA and the City of Quincy need to terminate the Funding Agreement. However, IHDA will be allowing the city to use these funds in a Strong Communities Program grant, which we will request permission to accept at a later date.

If you have any questions, please let me know.

RESOLUTION

WHEREAS, the Illinois Housing Development Authority (IHDA) and the City of Quincy are parties to a certain Program Funding Agreement dated August 6, 2021 (the "Funding Agreement") for a grant in an amount not to exceed **Fifty Thousand Dollars and No/100 Dollars (\$50,000.00)** (the "Funds") for the maintenance and demolition of Abandoned Residential Property under the Abandoned Residential Property Municipality Relief Program; and

WHEREAS, the City of Quincy did expend, and the Authority did disburse, **Zero and No/100 Dollars (\$0)** ("Expended Funds") of the Funds; and

WHEREAS, the Supreme Court of Illinois ("Court") issued an opinion on June 17, 2021, ruling that the statutory framework funding the Abandoned Residential Property Municipality Relief Program is unconstitutional; and

WHEREAS, IHDA is no longer able to operate the Abandoned Residential Property Municipality Relief Program due to the Court's ruling; and

WHEREAS, IHDA and the City of Quincy desire to terminate the Funding Agreement, except as expressly stated herein.

NOW THEREFORE, in consideration of the mutual covenants contained herein and for other good and valuable consideration, the receipt and sufficiency of which is acknowledged, the Illinois Housing Development Authority and the City of Quincy agree as follows: That the Funding Agreement shall be terminated in its entirety and shall be of no further force and effect and the City of Quincy shall have no further obligations under the Funding Agreement; and further, that the Illinois Housing Development Authority does not owe, nor shall make, any additional disbursement of any of the Funds to the City of Quincy.

Adopted this _____ day of _____, 2022.

City Clerk

Approved this _____ day of _____, 2022.

Mayor

RESOLUTION

WHEREAS, the Illinois Housing Development Authority (IHDA) and the City of Quincy are parties to a certain Program Funding Agreement dated August 6, 2021 (the “Funding Agreement”) for a grant in an amount not to exceed **Fifty Thousand Dollars and No/100 Dollars (\$50,000.00)** (the “Funds”) for the maintenance and demolition of Abandoned Residential Property under the Abandoned Residential Property Municipality Relief Program; and

WHEREAS, the City of Quincy did expend, and the Authority did disburse, **Zero and No/100 Dollars (\$0)** (“Expended Funds”) of the Funds; and

WHEREAS, the Supreme Court of Illinois (“Court”) issued an opinion on June 17, 2021, ruling that the statutory framework funding the Abandoned Residential Property Municipality Relief Program is unconstitutional; and

WHEREAS, IHDA is no longer able to operate the Abandoned Residential Property Municipality Relief Program due to the Court’s ruling; and

WHEREAS, IHDA and the City of Quincy desire to terminate the Funding Agreement, except as expressly stated herein.

NOW THEREFORE, in consideration of the mutual covenants contained herein and for other good and valuable consideration, the receipt and sufficiency of which is acknowledged, the Illinois Housing Development Authority and the City of Quincy agree as follows: That the Funding Agreement shall be terminated in its entirety and shall be of no further force and effect and the City of Quincy shall have no further obligations under the Funding Agreement; and further, that the Illinois Housing Development Authority does not owe, nor shall make, any additional disbursement of any of the Funds to the City of Quincy.

Adopted this _____ day of _____, 2022.

City Clerk

Approved this _____ day of _____, 2022.

Mayor

ORDINANCE NO. ____

**AN ORDINANCE AMENDING THE DISTRICT MAP
WHICH IS MADE A PART OF SECTION 162.002 OF THE
MUNICIPAL CODE OF THE CITY OF QUINCY OF 2015**

BE IT ORDAINED BY THE CITY COUNCIL OF THE CITY OF QUINCY, IN ADAMS COUNTY, ILLINOIS, as follows:

Section 1. That the district map, which is made a part of Section 162.002 of the Municipal Code of the City of Quincy of 2015, be and hereby is amended to change the present C1B (Commercial) Zoning District to the C2 (Commercial) Zoning District for the following properties:

Part of the East 45 acres of the South One Half (1/2) of the Southeast Quarter of Section 32, in Township One (1) South of the Base Line and in Range Eight (8) West of the Fourth Principal Meridian in Adams County, Illinois and being more particularly bounded and described as follows:

Commencing at a point on the South line of said Southeast Quarter which is North 89 degrees 40 minutes East along said South line 2278.20 feet from a stone marking the Southwest corner of said Southeast Quarter, thence North 00 degrees 30 minutes West 375 feet, thence North 89 degrees 40 minutes East 50 feet, thence South 00 degrees 30 minutes East 375 feet to a point on the South line of said Southeast Quarter, thence South 89 degrees 40' West along said South line 50 feet to the point of beginning, containing 0.53 acres, inclusive and being subject to a part of the Right of Way State Round #104 lying along the South side thereof,

And

Commencing at a point on the South line of said Southeast Quarter which is North 89 degrees 40 minutes East along said South line 2328.20 feet from a stone marking the Southwest corner of said Southeast Quarter, thence North 00 degrees 30 minutes West 375 feet, thence North 89 degrees 40 minutes East 300 feet, thence south 00 degrees 30 minutes East 375 feet to a point on the south line of said Southeast quarter, thence South 89 degrees 40 minutes West along said South line 300 feet to the point of beginning, containing 2.58 acres, inclusive and being subject to a part of the R.O.W. of State Route #104 laying along the South side thereof, all situated in the County of Adams, in the State of Illinois

P.I.N.: 23-8-0886-001-00 (commonly known as 4701-4729 Broadway Street, Quincy, IL 62305).

Section 2. All ordinances and parts of ordinances in conflict with the provisions of this ordinance shall be, and the same are, to the extent of such conflict, hereby repealed.

Section 3. This ordinance shall be in full force and effect from and after its passage, approval and publication, as provided by law.

ADOPTED:

CITY CLERK

APPROVED:

MAYOR

Officially published in pamphlet form this day of , 2022.

THE CITY COUNCIL

OFFICIAL PROCEEDINGS

REGULAR MEETING

Quincy, Illinois, February 28, 2022

The regular meeting of the City Council was held this day at 7:00 p.m. with Mayor Michael A. Troup presiding.

The following members were physically present:

Ald. Fletcher, Entrup, Bergman, Bauer, Mays, Freiburg, Sassen, Rein, Mast, Reis, Averkamp, Uzelac, Holtschlag. 13.

Absent: Ald. Farha. 1.

Ald. Rein moved Ald. Farha be excused from this meeting. Motion carried.

The minutes of the regular meeting of the City Council held February 22, 2022, were approved as printed on a motion of Ald. Entrup. Motion carried.

Legal Counsel: Corporation Counsel Lonnie Dunn.

PUBLIC FORUM

Dennis Williams asked the City Council to reappoint Kerry Anders to the Fire & Police Commission and to give him his full term.

Cecil Weathers asked the council to table the appointment and allow Kerry Anders to finish out his term as Fire & Police Commissioner.

Louis Seaver, 1707 N. 12th, stated it is a privilege to come to the City Council meetings and wanted to thank the elected officials, department heads and employees of the City.

PETITIONS

Special Event Application by Early Childhood and Family Center, 401 South 8th St. requesting permission to hold the Week of the Young Child student parade at 10:00 a.m. and 1:30 p.m. on April 4, 2022. They request closure of following streets for 25 minutes for each parade: 8th St., Kentucky to State, 9th Kentucky to State, Kentucky 8th to 9th and State 8th to 9th Streets. They requests barricades and assistance in closing the intersections and diverting traffic as needed. Applicant has submitted all of the required documentation and approval is recommended by the Department of Utilities & Engineering.

Ald. Holtschlag moved the prayer of the petition be granted and the proper authorities notified. Motion carried.

Special Event Application from Quincy Public Schools Foundation Broad of Trustees requesting permission to hold the 9th Annual Dream Big Color Fun Run on April 23, 2022.

The following street closures are requested from 8:30 a.m. until 11:00 a.m.: Maine St 16th to 33rd St, 16th St. Maine to Jersey, Jersey 16th St to East Ave, York Street, East Ave to 23rd St, 23rd York to Maine St. They request barricades for street closures and "No Parking" signs along the race route by 5:00 p.m. on April 22nd. Auxiliary Police Officers are requested at the intersections of 24th and Maine and 30th and Maine. Applicant has submitted all of the required documentation and approval is recommended by the Department of Utilities & Engineering.

Ald. Sassen moved the prayer of the petition be granted and the proper authorities notified. Motion carried.

REPORTS OF PLAN COMMISSION

Recommending approval to rezone an approximately 38,000 square foot section of property located at 4701-4729 Broadway Street from C1B (Commercial) to C2 (Commercial) to establish the same zoning classification (C2) as the remaining approximately 90,000 square feet of property at 4701-4729 Broadway Street.

Ald. Freiburg moved the report be received and concurred in and an ordinance drafted. Motion carried.

Recommending approval to rezone the property at 1111 North 8th Street from R2 (Two-Family Residential) to R3 (Multi-Family Residential) to allow for use as a sober living house, which is considered a halfway house in the City of Quincy's Municipal Code.

Ald. Bergman moved the report be received and concurred in and an ordinance drafted. Motion carried.

MAYOR'S APPOINTMENTS

By Mayor Michael A. Troup making the appointment of Jason Finney to the Fire and Police Commission, effective immediately for a three-year term ending February 14, 2025, tabled for two weeks by Ald. Rein.

Ald. Rein moved the appointment be tabled indefinitely, seconded by Ald. Sassen. Motion carried.

By Mayor Michael A. Troup making the appointment of Michael (Mike) McLaughlin to the Fire and Police Commission, effective Monday February 28, 2022, for a three-year term ending February 28, 2025.

Ald. Rein moved the appointment be confirmed, seconded by Ald. Mays, and on the roll call the following vote resulted: Yeas: Ald. Fletcher, Bergman, Mays, Freiburg, Sassen, Rein, Holtschlag. 7. Nays: Ald. Entrup, Bauer, Reis, Awerkamp, Uzelac. 5. Present: Ald. Mast. Absent: Ald. Farha. 1. The Mayor cast a vote of yea. Motion carried.

RESOLUTION

Central Services Director and the Central Services Committee recommending approval of a payment to Rock Line Products Inc. of Botkins, OH, in the amount of \$17,195 to purchase a flat trailer for the City's asphalt seam machine, tabled for one week by Ald. Sassen.

Ald. Sassen moved to table the resolution indefinitely, seconded by Ald. Rein. Motion carried.

RESOLUTION

WHEREAS, the Central Services Department is needing to purchase a flat bed trailer; and

WHEREAS, this trailer will be used to haul the asphalt seam repair machine; and

WHEREAS, this is a 2016 flat bed trailer with a purchase price of \$9,000 and meets our requirements; and

WHEREAS, funding for the purchase of this trailer is available in the Capital Fund fiscal year budget; now

THEREFORE BE IT RESOLVED, the Central Services Director and the Central Services Committee recommends to the Mayor and City Council that the purchase of the flat bed trailer from United Rentals of Quincy, Illinois, in the amount of \$9,000 be accepted.

Kevin McClean

Director of Central Services

Ald. Sassen moved for the adoption of the resolution, seconded by Ald. Holtschlag, and on the roll call each of the 13 Aldermen voted yea, with 1 absent. Motion carried.

RESOLUTION

WHEREAS, the American Rescue Plan Act of 2021 is designed to facilitate the United States' recovery from the devastating economic and health effects of the COVID-19 pandemic; and,

WHEREAS, The Coronavirus State and Local Fiscal Recovery Funds (SLFRF) program, a part of the American Rescue Plan, delivers \$350 billion to state, local, and Tribal governments across the country to support their response to and recovery from the COVID-19 public health emergency; and,

WHEREAS, the City of Quincy has a population under 50,000 and is considered a CDBG Entitlement Community, and will be receiving funds directly from the U.S. Department of Treasury; and,

WHEREAS, the City received \$2.7 million in September 2021, and expects an additional \$2.7 million in September 2022, and funds must be expended by December 31, 2024; and,

WHEREAS, Cities can use ARPA funds to address the negative economic impacts caused by the public health emergency; replace lost public sector revenue; provide premium pay for essential workers; and invest in water, sewer, and broadband infrastructure; and,

WHEREAS, the City wishes to create a new capital projects Fund #317 called "American Rescue Plan Fund" to account for all revenues and expenses; and,

NOW, THEREFORE, BE IT HEREBY RESOLVED by City Council that it desires the City's Comptroller to create a new capital projects fund #317 called the "American Rescue Plan Fund" and direct any American Rescue Plan Act receipts into this fund.

Ald. Sassen moved for the adoption of the resolution, seconded by Ald. Holtschlag, and on the roll call each of the 13 Aldermen voted yea, with 1 absent. Motion carried.

RESOLUTION

WHEREAS, the provision of public transit service is essential to the people of Illinois; and

WHEREAS, 49 U.S.C. § 5311 ("Section 5311"), makes funds available to the State of Illinois to help offset certain operating deficits and administrative expenses of a system providing public transit service in non-urbanized areas; and

WHEREAS, the Downstate Public Transportation Act (30 ILCS 740/2-1 et seq.) ("Act") authorizes the State of Illinois, acting by and through the Illinois Department of Transportation, to provide grants and make funds available to assist in the development and operation of public transportation systems; and

WHEREAS, grants for said funds will impose certain obligations upon the recipient, including the provision by it of the local share of funds necessary to cover costs not covered by funds provided under Section 5311 or the Act.

NOW, THEREFORE, BE IT RESOLVED BY THE GOVERNING COUNCIL OF THE CITY OF QUINCY:

Section 1. That an application be made to the Division of Public and Intermodal Transportation, Department of Transportation, State of Illinois, for a financial assistance grant under Section 5311 and the Act for fiscal year 2023, for the purpose of off-setting a portion of the Public Transportation Program operating expenses and deficits of Quincy Transit Lines.

Section 2. That while participating in said operating assistance program, the *City of Quincy on behalf of Quincy Transit Lines* will provide all required local matching funds.

Section 3. *The Mayor of the City of Quincy and/or the Director of Quincy Transit Lines* is hereby authorized and directed to execute and file on behalf of the *Quincy Transit Lines* such application.

Section 4. *The Mayor of the City of Quincy and/or the Director of Quincy Transit Lines* is authorized to furnish such additional information as may be required by the Division of Public and Intermodal Transportation and the Federal Transit Administration in connection with the aforesaid application for said grant.

Section 5. *The Mayor of the City of Quincy and/or the Director of Quincy Transit Lines* is hereby authorized and directed to execute and file on behalf of the Quincy Transit Lines a Section 5311-Downstate Operating Assistance Grant Agreement (“Agreement”) with the Illinois Department of Transportation and amend such Agreement, if necessary, in order to obtain grant assistance under the provisions of Section 5311 and the Act for fiscal year 2023.

Section 6. *The Mayor of the City and/or the Director of Quincy Transit Lines* is hereby authorized to provide such information and to file such documents as may be required to perform the Agreement and to receive the grant for fiscal year 2023.

PRESENTED and ADOPTED this 28th day of February, 2022.

Signed By

Michael A. Troup

Mayor, City of Quincy

ATTESTED

Laura Oakman

Quincy City Clerk

Ald. Rein moved for the adoption of the resolution, seconded by Ald. Sassen, and on the roll call each of the 13 Aldermen voted yea, with 1 absent. Motion carried.

RESOLUTION

WHEREAS, the heating portion of a rooftop HVAC unit at Central Fire Station at 906 Vermont has stopped working due to multiple issues including a cracked heat exchanger; and,

WHEREAS, the current temperatures necessitate the need for a heating unit and parts to fix this portion are at least 8 weeks out and Peters Heating and Air Conditioning have an available unit to replace the existing unit within the next two weeks; and,

WHEREAS, the unit is 10 years old and nearing its life expectancy for the remainder of the unit; and,

WHEREAS, Peters Heating and Air Conditioning is qualified and available to make the emergency repair under Section 2-7 of the Purchasing Manual adopted by Section 44.001 of the Municipal Code; and,

WHEREAS, the department has sufficient funds in the current budget for this purchase; and

NOW THEREFORE BE IT RESOLVED, that the Fire Chief, the Purchasing Manager and the Director of Administrative Services recommend to the Mayor and the City Council that the proposal from Peters Heating and Air Conditioning, Inc., be accepted in the amount of \$10,468.00 for the replacement of this HVAC unit.

Bernard Vahlkamp

Fire Chief

Ald. Bergman moved for the adoption of the resolution, seconded by Ald. Freiburg, and on the roll call each of the 13 Aldermen voted yea, with 1 absent. Motion carried.

ORDINANCE

Adoption of an Ordinance entitled: An Ordinance Amending The 2021-2022 Fiscal Year Budget (Increase/Decrease Revenues in Recycle and Central Garage Funds).

Ald. Entrup moved for the adoption of the ordinance, seconded by Ald. Uzelac, and on the roll call each of the 13 Aldermen voted yea, with 1 absent.

The Chair, Mayor Michael A. Troup, declared the motion carried and the ordinance adopted.

ORDINANCE

Adoption of an Ordinance entitled: An Ordinance Authorizing Lease Agreement (North Side Boat Club).

Ald. Freiburg moved to amend the Lease (Exhibit A) by substituting the following new language:

The terms “Boat Club Facilities,” Boat Facilities” and “Facilities” shall be deleted from the Lease and replaced with the term “Premises.”

Article I, Paragraph A, shall be amended to delete all words after the word “above” and be replaced with the following: “and more generally known as 200 South Front Street, Quincy, IL 62301.”

Article III, Paragraph B, shall be deleted in its entirety and replaced with the Renewal Option paragraph contained in the previous lease that was approved by this council on March 2, 2015 (Ordinance No. 15-8): “B. RENEWAL OPTION. The Lessee hereunder shall have the right and privilege to renew this Lease for one (1), ten (10) year period, provided that the Lessee shall be required to give written notice of its intent to exercise such renewal option to the City as provided under Article VII, Paragraph D of this Lease at least six (6) months prior to the expiration of same or of any extension thereof”;

Except that the words “Article VII, Paragraph D” shall be replaced with “Article VIII. Paragraph B”;

Thereafter, the following sentence shall be added to the end of such Paragraph B: “It is hereby agreed by the parties that the rental fee set forth in Article IV (A) shall be the same for any option to renew this Lease,” seconded by Ald. Sassen. Motion carried.

Ald. Freiburg moved for the adoption of the ordinance, as amended, seconded by Ald. Sassen, and on the roll call each of the 13 Aldermen voted yea, with 1 absent.

The Chair, Mayor Michael A. Troup, declared the motion carried and the ordinance adopted, as amended.

ORDINANCE

First presentation of an Ordinance entitled: An Ordinance Amending The District Map Which Is Made A Part Of Section 162.002 Of The Municipal Code Of The City Of Quincy Of 2015. (To change the present R2 (Two Family) Zoning District to the R3 (Multi-Family) Zoning District 1111 North 8th Street).

Ald. Entrup moved the requirements of Section 32.31 of the City Code of the City of Quincy be waived and the ordinance adopted, seconded by Ald. Sassen, and on the roll call each of the 13 Aldermen voted yea, with 1 absent.

The Chair, Mayor Michael A. Troup, declared the motion carried and the ordinance adopted.

REPORT OF PLAN COMMISSION

Recommending approval of a Special Permit for Recovery Anonymous to operate a sober living house at 1111 North 8th Street, which is considered a halfway house in the city of Quincy’s Municipal Code with the following condition: That the City Council waive the requirement in City Code Chapter 162.030(B) that there must be 800 feet between a halfway house and any pre-existing day care, preschool, private or public school, college, or vocational school.

Ald. Entrup moved the report be received and concurred in. Motion carried.

REPORT OF FINANCE COMMITTEE

Quincy, Illinois, February 28, 2022

	Transfers	Expenditures	Payroll
City Hall.....		2,306.58	
Building Maintenance.....		5,212.40	
Comptroller.....		458.00	
Legal Department.....		6,034.25	
IT Department.....		8,085.95	
Police Department.....		13,273.31	
Fire Department.....		6,518.75	
Public Works.....		355.13	
Engineering.....		8,475.37	
Tax Distribution/Subsidies.....		138,228.29	
GENERAL FUND SUBTOTAL	0.00	188,948.03	0.00
Planning and Devel.....		170.36	
911 Surcharge Fund.....		460.98	
Traffic Signal Fund.....		1,247.48	
Econ Dev Growth Fund.....		700.00	
Transit Fund.....		610.95	
Capital Projects Fund.....		16,040.75	
To 511 Airport.....		73,000.00	

Water Fund		72,759.21	
Sewer Fund		92,280.22	
Quincy Regional Airport Fund		761,537.92	
Airport P.F.C. Fund		5,948.31	
Garbage Fund.....		92.10	
Recycle Fund		200.00	
Central Garage		13,943.88	
Self Insurance		11,762.08	
Health Insurance Fund		213,013.94	
Econ Dev Revolv Loan Fund		4,204.55	
BANK 01 TOTALS	73,000.00	1,385,443.09	0.00
Motor Fuel Tax		35,802.81	
ALL FUNDS TOTALS.....	73,000.00	1,421,245.90	0.00

Jack Holtschlag
Anthony E. Sassen
Mike Rein
Richie Reis

Finance Committee

Ald. Rein, seconded by Ald. Sassen, moved the reports be received and vouchers be issued for the various amounts and on a roll call each of the 13 Aldermen voted yea, with 1 absent. Motion carried.

REVENUE PRESENTATION

City Comptroller, Sheri Ray, gave a Power Point Revenue Projection Presentation.

The City Council adjourned at 8:05 p.m. on a motion of Ald. Holtschlag. Motion carried.

LAURA OAKMAN
City Clerk

AGENDA

**FIRE ALDERMANIC MEETING
MONDAY, March 7, 2022
City Hall Annex 706 Maine St.
3rd Floor P & D Conference Room
6:15 PM**

Items of Discussion

1. Public Comments (limit 3 minutes)
2. Presentation related to the proposed adoption of updated Fire and Building Codes.
3. Proposed 2022-2023 Budget Discussion



**PERSONNEL
COMMITTEE MEETING NOTICE**

Monday, March 7, 2022
4:00 PM

A Personnel Committee meeting will be held Monday, March 7th, 2022 in the Caucus Conference Room of City Hall at 4:00 p.m.

Agenda

1. Call Meeting to Order
2. Approval of Minutes
3. Public Comment (3 minutes)
4. Job Description Updates Approval
5. Cell Phone Policy Update
6. Proposed Shortened Deductible for May 2022 – December 2022
7. Late Additions

Respectfully submitted,

Carrie Potter
Human Resources Manager



MEETING NOTICE CITY HALL COMMITTEE

A meeting of the City Hall Committee will be held on Monday, March 7, 2022 at 6:30 p.m. in the Engineering Department Conference Room #235.

Agenda

1. Call Meeting to Order
2. Public Comment (3 Minutes)
3. New Business
 - a. City Hall Plaza Stairs Replacement
 - b. Late Additions
4. Adjournment

Respectfully submitted,

Jeffrey Conte, P.E.
Director of Utilities & Engineering